

# GIANT Power Halo User Manual

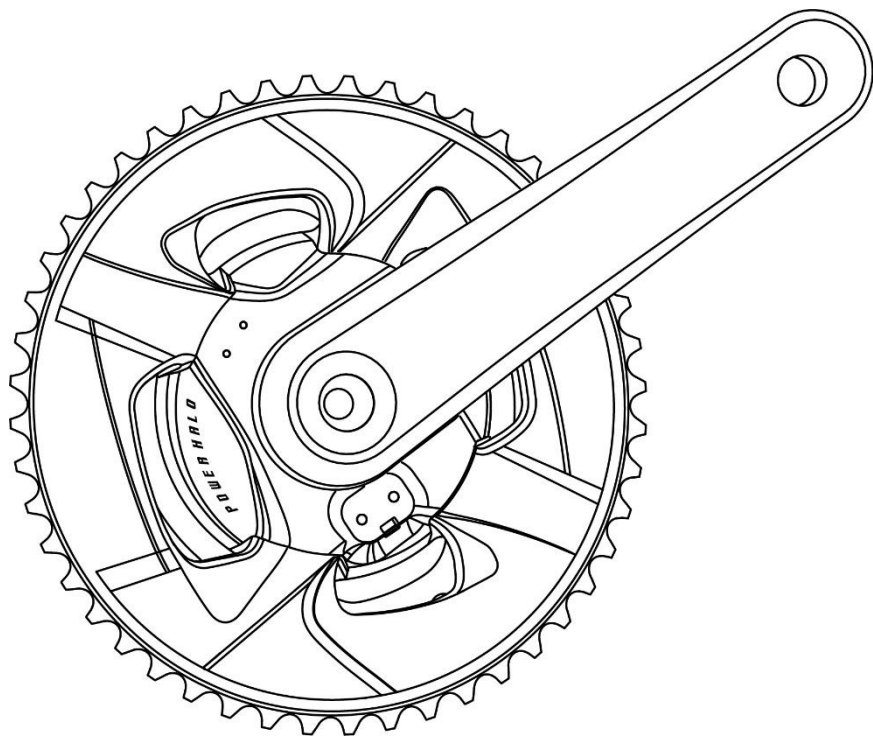

## INTRODUCTION

Congratulations on the purchase of your new Giant Power Halo. The all-new Giant Power Halo is a spider-based power meter, which is widely compatible to different chainrings and delivers real-time accurate information with an integrated system that's precise, reliable and easy to set up.

The most effective training is smart training, so start training with power!

## PRODUCT ANATOMY

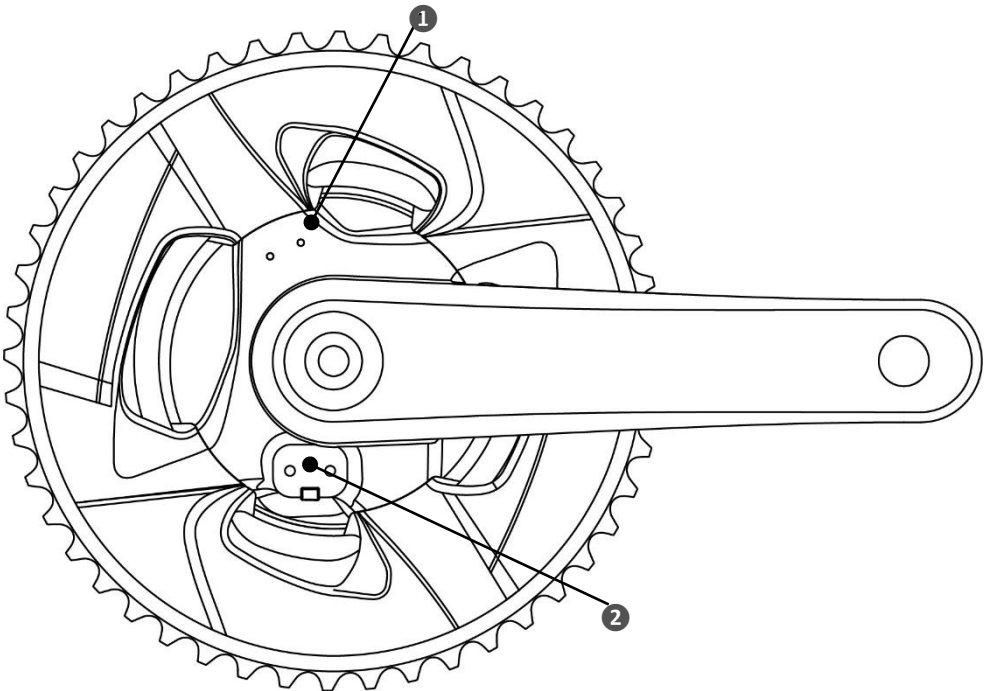

- ① LED INDICATION LIGHT
- ② MAGNETIC CHARGING PORT

## CHARGING CABLE

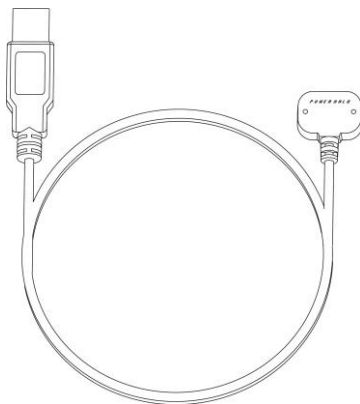

Every Power Halo comes with a dedicated charging cable. Please make sure that this cable is included when purchasing Power Halo.

Please note that the USB charger is not included.

## LED INDICATIONS

There is a LED indicator light on every Giant Power Halo. This indicator light shows various conditions.

When waking up Power Halo by rotating the crank arm backwards two or three full turns:

- Indicator light blinks GREEN 10 times    ● ● ● ● ●    Battery capacity is more than    60%
- Indicator light blinks ORANGE 10 times    ● ● ● ● ●    Battery capacity is between    30~60%
- Indicator light blinks RED 10 times    ● ● ● ● ●    Battery capacity is less than    30%

While charging:

- Indicator light is RED    ● ● ● ● ●    Charging is in progress.
- Indicator light is GREEN    ● ● ● ● ●    Charging is complete.

Indicator light does not light up or blink:

The battery may be damaged or the unit has other problems, please contact an authorized Giant retailer for assistance.

## IMPORTANT NOTICE BEFORE RIDING

We strongly urge you to read the Bicycle Owner's Manual thoroughly before your first ride. Read and make sure that you understand every point in this manual, especially the "Safety" section. If you have any questions, please contact your local authorized Giant retailer.

This user manual contains important safety, performance, and service information. Please read the user manual before starting to use your new Giant Power Halo and keep it for future reference.

For your safety, we recommend that you to focus on your surroundings while riding. Avoid staring at the cycle computer or smartphone screen. This may compromise your traffic awareness, and possibly lead to serious accident.

## SERVICE AND TECHNICAL SUPPORT

If you encounter difficulties or are uncertain about anything mentioned in this user manual, please contact an authorized Giant retailer



or visit: <https://www.giant-bicycles.com/global/power-halo>



For more information, please visit:

<https://www.giant-bicycles.com/global/manuals>

To find a dealer or to learn more about Giant, please visit: [www.giant-bicycles.com](http://www.giant-bicycles.com)

## QUICK START

### 1. CHARGING THE BATTERY

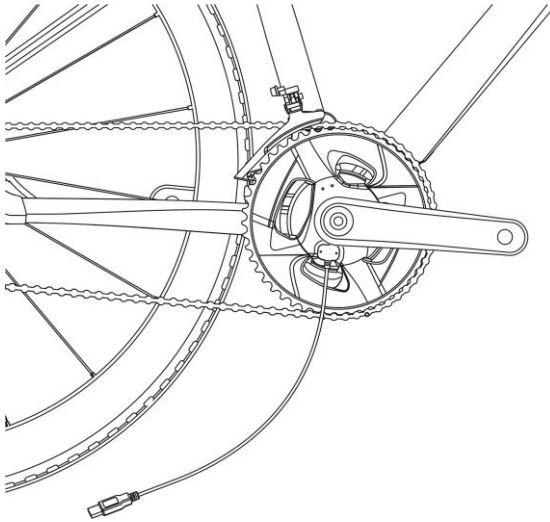

Connect the charging cable to a USB power source. For best results, we recommend using a dedicated USB charger with output current of 1~2A.

Connect the cable to the charging port on GIANT Power Halo. The unit should start charging immediately.

Fully charge the battery of Power Halo before using it for the first time.

Indicator light is RED ●●●●●: Charging is in progress.

Indicator light is GREEN ●●●●●: Charging is complete.

#### **⚠ CAUTION**

Input voltage: 5V±10%

Input current: 1~2A

Charging time: approximately 1 hour for a full charge.

The battery should fully recharged once every two months when Power Halo is not being used for a longer time.

## 2. PAIRING WITH CYCLING COMPUTER OR RIDELINK APP

GIANT Power Halo is compatible with cycling computers that have BLUETOOTH and ANT+ functions and ability to record power information.

1. Rotate the crank arm backwards two or three full turns to wake up Giant Power Halo.
2. The Indicator light blinks showing it's battery status.
3. Refer to the user manual of the cycling computer to pair with Power Halo. The pairing procedures may differ between various brands.

Alternatively, Power Halo can also be paired with GIANT RIDELINK App via your smart phone. The pairing procedure is similar:

1. Download and install the GIANT RIDELINK App from Google Play(Android) or App Store(iOS)
2. Rotate the crank arm backwards two or three full turns to wake up Giant Power Halo.
3. The Indicator light blinks showing it's battery status.
4. Follow the instructions from the GIANT RIDELINK App to pair with Power Halo.

## 3. CALIBRATE/ZERO OFFSET OF POWER HALO

For best results, it is recommended to perform the calibration procedure before every ride.

Before the calibration, keep the drive side crank arm in 12 o'clock position while the bike is positioned horizontally. Leave the crank in stationary position.

Do not attempt the calibration procedure while you're on the bike. Do not apply any force on the pedals.

Refer to the manufacturer's user manual of the cycling computer to calibrate with Giant Power Halo. The procedures may differ between different computer brands.

If the RideLink App is to be used, follow the instructions in the app to perform the calibration

During the process of calibration, the indicator light blinks BLUE ●•●•● for a few times.

Once the calibration is successful, you may get a confirmation message "successful" or "0" from the computer.

You're now ready to Ride With POWER!

## RIDELINK APP

Giant continuously keeps developing and releasing the updated versions of firmware to provide the latest functionalities. The latest firmware version for Giant Power Halo can be updated by using Giant RideLink App.

The Giant RideLink App is available for Apple® iOS and Android system. Please go to the App Store® or Google Play to search Giant RideLink App and download it.



## SPECIFICATIONS

<b>Bolt Circle Diameter (BCD)</b>	107mm
<b>Compatible crank</b>	SRAM DUB, Direct Mount, 8 bolts
<b>Connections (BLE/ANT+)</b>	BLE/ANT+
<b>Battery type</b>	Lithium-ion
<b>Battery running time</b>	100 hours
<b>Battery charge time</b>	1 hour
<b>Battery life indicator (Y/N)</b>	Yes
<b>Accuracy</b>	± 1.5%
<b>Temperature compensation</b>	Yes
<b>Left/Right balance (Y/N)</b>	Yes
<b>Firmware APP</b>	RideLink
<b>Water resistance capability</b>	IPX7
<b>Intended use</b>	Road, Gravel cycling

## MAINTENANCE AND WATER RESISTANCE

To ensure the functionalities of Giant Power Halo and not to affect the Giant limited warranty, please make sure to comply with the WARNINGS and CAUTIONS listed below. Not complying with these may result in damaging Giant Power Halo and void your warranty.

The water resistance level of Giant Power Halo complies with the IPX7 rating.

### ⚠ WARNING

Do NOT immerse Power Halo in water.

Do NOT use the high pressure washers to clean the power meter directly. The high pressure will cause the moisture to permeate the internals of the power meter and damage the electronic components.

Do NOT disassemble Power Halo, this will void your warranty.

Only clean the cover of power meter with a clean cloth and water. Please do NOT use chemical detergent to clean as it may damage the cover.

Do NOT expose Power Halo to constant high temperatures.

Avoid that Power Halo gets hit by any abnormal external force which may cause damage to the components.

Stop charging immediately to avoid dangerous situations if a strange smell, smoke, or any other abnormal condition occurs during charging.

Do not charge the battery in a wet environment or during a thunderstorm. It may cause damage to the battery and possible dangerous situations such as an electric shock.

Make sure that no metal items or oily materials that short the charging connectors or charging terminals.



**⚠ CAUTION**

The storage environment temperature range is between  $-30^{\circ}\text{C} \sim 80^{\circ}\text{C}$  /  $-22^{\circ}\text{F} \sim 176^{\circ}\text{F}$ . Damage to the electronic components may occur if the storage temperature is out of range.

The operating environment temperature range is between  $-20^{\circ}\text{C} \sim 50^{\circ}\text{C}$  /  $-4^{\circ}\text{F} \sim 122^{\circ}\text{F}$ . The functions may not be normal when the temperature is out of range.

The environment temperature should be between  $-20^{\circ}\text{C} \sim 50^{\circ}\text{C}$  /  $-4^{\circ}\text{F} \sim 122^{\circ}\text{F}$  when charging the battery. The battery may get damaged when the environment temperature is out of range.

Only use the charging cable which is supplied with Power Halo. Do not bundle the charging cable while charging. Do not pull or damage the charging cable in any way. Using a damaged charging cable may cause danger.

Follow the suggested voltage and current:  $5\text{V} \pm 10\% / 1 \sim 2\text{A}$ .

Charging time is around 1 hour. If the charging time is over 1 hour and the battery is still not fully charged, stop charging to avoid the risk of overheating the battery. Please contact your local authorized Giant retailer for support and advice.

The battery should be fully recharged once every two months when the Power meter is not being used for a longer time.

The battery may get damaged if it does not get charged at low battery level. Charge it at any time.

It is a normal phenomenon that the battery level will gradually reduce when it has not being used for a period of time.

A loss of no more than 30% of its original nominal capacity at a maximum of 400 charges is to be expected.

## GIANT LIMITED WARRANTY

Giant warrants its power meter for a period of two (2) years from the date of purchase, this applies only for the original owner. This warranty applies only to this product when purchased new from an Authorized Giant Dealer and assembled by that dealer at the time of purchase.

### 1. LIMITED REMEDY

Unless otherwise provided, the sole remedy under the above warranty, or any implied warranty, is limited to the replacement of defective parts with those of equal or greater value at the sole discretion of Giant. This warranty extends from the date of purchase, applies only to the original owner, and is not transferable. In no event shall Giant be responsible for any direct, incidental or consequential damages, including, without limitation, damages for personal injury, property damage, or economic losses, whether based on contract, warranty, negligence, product liability, or any other theory.

### 2. EXCLUSIONS

2.1. The above warranty, or any implied warranty, does not cover:

- Normal wear and tear on parts in situations where there are no assembly or material defects.
- Consumable components including bolts and charging cable.
- Products serviced by other than an Authorized Giant dealer.
- Modifications of the product from its original condition.
- Use of this product for abnormal, competition and/or commercial activities or for purposes other than those for which this product was designed.
- Damage caused by failing to follow the User's Manual.
- Paint, finish and decal damage resulting from taking part in competitions, jumping, downhill and/or training for such activities or events or as a result of exposing the product to, or operating the product in, severe conditions or climates.
- Labor charges for part replacement or changeover.

2.2. Except as is provided by this warranty and subject to all additional warranties, Giant and its employees and agents shall not be liable for any loss or damage whatsoever (including incidental and consequential loss or damage caused by negligence or default) arising from or concerning any Giant product.

2.3. Giant makes no other warranties, express or implied. All implied warranties, including the warranties of merchantability and fitness for a particular purpose are limited in duration to that

of the express warranties stated above.

2.4. Any claim against this warranty must be made through an Authorized Giant Dealer or distributor. The purchase receipt or other proof of the date of purchase is required before a warranty claim may be processed.

2.5. Claims made outside the country of purchase may be subject to fees and additional restrictions. Warranty duration and details may differ by country. This warranty gives you specific legal rights, and you may also have other rights which may vary from place to place.

**THIS WARRANTY DOES NOT AFFECT YOUR STATUTORY RIGHTS.**