

🔌 E-BIKE MANUAL

# GETTING STARTED

V 8.2



[www.giant-bicycles.com/global/manuals](http://www.giant-bicycles.com/global/manuals)



[www.liv-cycling.com/global/manuals](http://www.liv-cycling.com/global/manuals)



[www.momentum-biking.com/global/manuals](http://www.momentum-biking.com/global/manuals)

# Table of contents

<b>1 Preface.....</b>	<b>2</b>
<b>2 Safety.....</b>	<b>4</b>
<b>3 Using your bike.....</b>	<b>7</b>
3.1 EnergyPak.....	7
3.1.1 First use.....	7
3.1.2 EnergyPak Smart Integrated.....	7
3.1.3 EnergyPak Smart Compact.....	9
3.1.4 EnergyPak Smart 250.....	10
3.1.5 EnergyPak Side Release.....	10
3.1.6 EnergyPak Carrier.....	11
3.2 Charger.....	12
3.2.1 Smart Charger.....	13
3.2.2 Smart Charger Compact.....	15
3.2.3 Fast Charger.....	17
3.2.4 Charging.....	18
3.2.5 Charging time.....	20
3.3 Controls.....	21
3.3.1 RideControl Ergo.....	21
3.3.2 RideControl Ergo 2.....	25
3.3.3 RideControl Ergo 3.....	29
3.3.4 RideControl Dash.....	32
3.3.5 RideControl GO.....	37
3.3.6 RideDash EVO.....	41
3.3.7 STI Lever.....	45
3.4 Keys.....	45
3.5 Riding range.....	46
<b>4 Transport &amp; Storage.....</b>	<b>47</b>
<b>5 Maintenance.....</b>	<b>49</b>
<b>6 Disposal.....</b>	<b>51</b>
<b>7 Legal documentation.....</b>	<b>52</b>
7.1 Warranty.....	52
7.2 Exclusions.....	53
7.3 Conformity.....	53
7.4 Disclaimer.....	53
7.5 FCC.....	54
7.6 IC.....	54

# 1 Preface

## Welcome

Welcome and congratulations on your purchase of a new Giant, Liv or Momentum E-bike. The fun of pedalling is only moments away!

## How to use this manual

This document is intended as a short introduction to your new e-bike. It contains essential safety information, and provides a first look at some of the e-bike's main components and functions. Before using the e-bike, it is important to also visit the support section of the website, to view and/or download the extensive information available there. In addition to e-bike specific information, also make sure to read the general information in the Bicycle Owner's Manual.

## Illustrations

Illustrations shown in this document may differ in detail from the exact configuration on your particular e-bike model. The illustrations are a general reference for instruction and description purposes only.

## Symbols used in this manual



**WARNING:** Warns about a situation that can cause death, serious physical injury and/or heavy material damage if one does not obey the safety instructions.



**CAUTION:** Warns about a situation that can cause physical injury or material damage if one does not follow the safety instructions.



**NOTICE:** Provides important information to avoid problems.



**INFO:** Provides additional information.

## Information resources & downloads

GIANT: <https://www.giant-bicycles.com/global/manuals>



LIV: <https://www.liv-cycling.com/global/manuals>



MOMENTUM: <https://www.momentum-biking.com/global/manuals>



For information on other bicycle parts and warranty, consult the general bicycle owner's manual.

## Service and support

This manual is not intended to be an extensive reference book about service, maintenance or repairs. Please contact your dealer for service and technical support.

## 2 Safety

### Safe use of the bicycle

Before using the e-bike on the open road, ride the bike in a secure area to get acquainted with riding a bike with electric pedalling support. Try all settings on the bike and get familiar with the results.



#### **WARNING:**

- Keep both hands on the grips on the handlebar and the brake levers within reach while riding, to be able to immediately respond to any circumstance. Failing to do so can cause you to lose control over the bicycle.
- Before every ride, perform a pre-ride check of the technical state of the bike and all essential bike functions, like steering and braking.
- Make sure the battery is properly placed and locked.
- Ensure that all fasteners are properly tightened.
- Make sure that there are no worn or damaged parts that may fail during the ride.

### Battery and charger

Take all following information into account when handling the battery and the charger.



#### **WARNING:**

- Keep the battery away from children and pets.
- Keep the battery & charger away from water and open fire.
- Do not drop or subject the battery & charger to any big shocks.
- Charge the battery only with the charger that was supplied with the e-bike, or the spare-/replacement charger supplied by an official dealer.
- Do not use the battery & charger for other purposes.
- Never connect the battery's terminals with each other.
- Do not cover the battery & charger or place objects on top of it during charging.
- Do not leave the battery & charger unattended while charging.
- Disconnect the charger and the battery immediately if you notice a strange smell or smoke.
- In the unlikely case that the battery is on fire: NEVER try to put the fire out with water. Cover the fire with large amounts of sand, and call emergency services immediately.



**CAUTION:** Avoid contact with battery and charger during charging operation. The charger can become hot during charging.



**NOTICE:** When the battery has reached the end of the service life, it should be treated as hazardous waste material. It should not be disposed of in regular household trash. Ask your dealer for advice on proper disposal of the battery.

## Luggage carrier



**WARNING:** Always make sure that any luggage or child-seat feature fitted to the luggage carrier is securely fitted in accordance with the manufacturer's instructions, and that there are no loose straps or other items that can get caught in the wheel.



### **CAUTION:**

- Luggage can only be safely carried on the carrier(s). Do not attach luggage to any other part of the bike.
- The bicycle may behave differently (particularly with regard to steering and braking) when the luggage carrier is loaded.
- Maximum rear carrier capacity including EnergyPak: 22 kg.



### **NOTICE:**

- It is recommended to check and adjust positioning of reflectors and lamps such that these are not obscured when luggage is attached to the luggage carrier.
- On some bikes the battery holder and luggage carrier are combined. Please ensure that luggage is securely fixed to avoid damage to the battery and/or holder.



**INFO:** It is recommended distribute luggage evenly between the two sides of the luggage carrier.



### CAUTION:

- Always follow the child seat manufacturer's instructions for installation, usage and safety. Never modify any original parts of the E-bike to accommodate a child seat
- Never exceed the carrier load capacity and/or total permissible load weight of the E-bike as stated elsewhere in this user manual.
- Please be aware that the use of a child seat can cause extra load stress and increased wear on the E-bike's electric and/or mechanical parts.
- If a child seat is used, and the bike is fitted with a saddle with exposed coil springs underneath the saddle, there is a substantial risk that the child's fingers can get injured from getting trapped in the coil springs. Please take appropriate steps to prevent the trapping of the child's fingers.
- Always consult the documentation that came with a carrier and/or consult your local dealer for installing instructions, maximum load, torque specifications, parts specifications, maximum compatible wheel size, trailer- and child seat compatibility.
- For information about the name and address of the manufacturer, importer or representative, trademark, model and production batch number or reference, check the carrier's documentation and/or on the carrier itself.



## 3 Using your bike

### 3.1 EnergyPak

The EnergyPak is the rechargeable battery that powers the e-bike system. EnergyPaks vary in shape, size, energy capacity and compatibility. They can be mounted on different locations on the e-bike, depending on the e-bike model. An EnergyPak should be charged with the original charger that is supplied with the e-bike.



**NOTICE:**

- Not every EnergyPak type or version may be shown in this manual. Please refer to the support section of the website for more information on EnergyPaks.
- Exact technical specifications and other details for each EnergyPak can be found on the printed label on the EnergyPak.

#### 3.1.1 First use

- Each EnergyPak's system is deactivated by the factory before it ships out.
- An EnergyPak will not function until it is activated.
- An EnergyPak can be activated by charging it with the charger.
- It is recommended to fully charge a new EnergyPak before the first use.
- A new EnergyPak might not yet achieve maximum performance upon first use.
- EnergyPak performance stabilizes after few full cycles of discharging (by riding) and recharging.

#### 3.1.2 EnergyPak Smart Integrated

##### Description

- EnergyPak
- Charging socket
- Energy level indicator

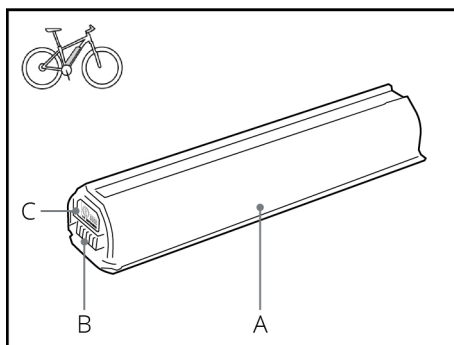



**NOTICE:** Always switch off the power first, before removing the EnergyPak.

### Removing the EnergyPak (Key Lock Type):

- Hold the battery in the frame to make sure it cannot drop when unlocking;
- Insert the key and unlock the EnergyPak. The EnergyPak will be ejected slightly
- - For top loading integrated batteries only: Lift out the EnergyPak to remove.
- Push the drop protection lever to fully unlock the EnergyPak;
- Remove the battery from the bike.

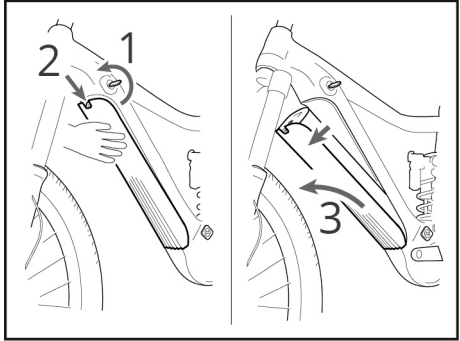

### Removing the EnergyPak (Torx Lock Type):

- Hold the battery in the frame to make sure it cannot drop when unlocking;
- Insert the Torx tool size 25 and turn counter-clockwise to release the EnergyPak (the screw is endless so it will not come out);
- Push the drop protection lever to fully unlock the EnergyPak;
- Remove the battery from the bike.

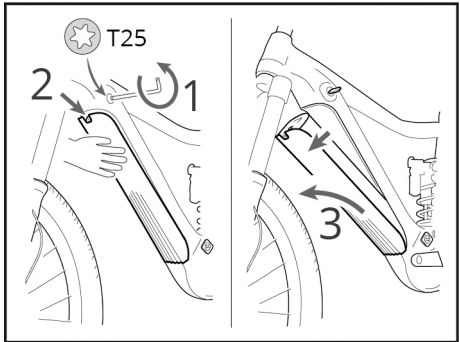

### Installing the EnergyPak

- Reverse removal procedure to install the EnergyPak.
- Make sure the connector slots are aligned correctly at the bottom;
- Push the top of the EnergyPak and make sure the EnergyPak is secured properly (a 'click' can be noticed while doing so);
- Pull out the key.

### 3.1.3 EnergyPak Smart Compact

#### Description

- A. EnergyPak
- B. Charging socket
- C. Energy level indicator

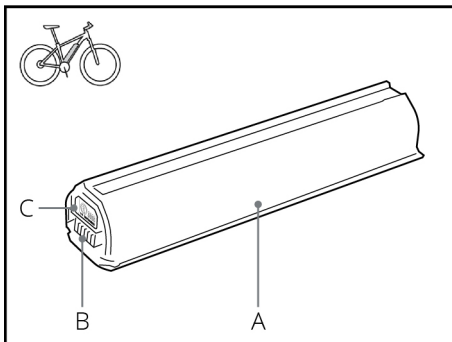

#### Installation & removal



**NOTICE:** Always switch off the power first, before removing the EnergyPak.

#### Removing the EnergyPak:

- Hold the battery in the frame to make sure it cannot drop when unlocking;
- Insert the key and unlock the EnergyPak. The EnergyPak will be ejected slightly;
- Remove the battery from the bike.

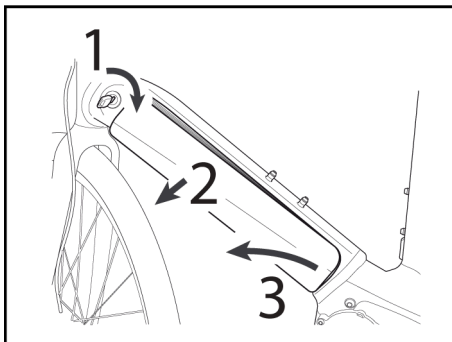

#### Installing the EnergyPak

- Reverse removal procedure to install the EnergyPak.
- Make sure the connector slots are aligned correctly at the bottom;
- Push the top of the EnergyPak and make sure the EnergyPak is secured properly (a 'click' can be noticed while doing so);
- Pull out the key;

### 3.1.4 EnergyPak Smart 250

#### Description

A. EnergyPak

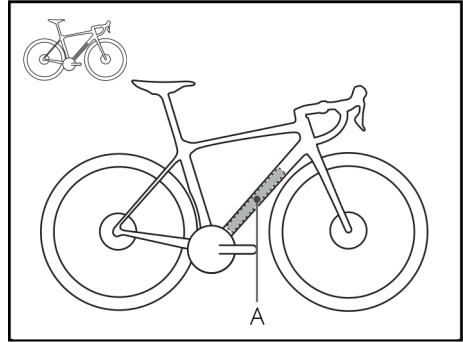

**NOTICE:** The EnergyPak Smart 250 can only be removed or installed by an authorized mechanic.

### 3.1.5 EnergyPak Side Release

#### Description

- A. EnergyPak
- B. Charging socket
- C. Energy level indicator

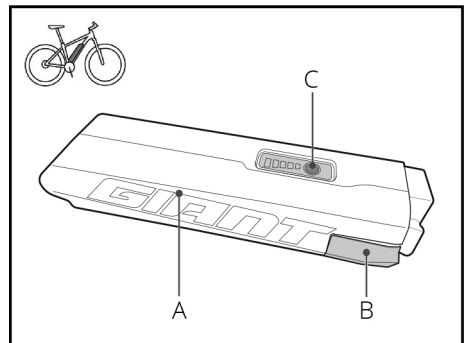

#### Installation & removal



**NOTICE:** Always switch off the power first, before removing the EnergyPak.

### Removing the EnergyPak:

- Hold the battery in the frame to make sure it cannot drop when unlocking;
- Insert the key and unlock the EnergyPak
- Pull the top of the EnergyPak sideways;
- Lift it out to remove the EnergyPak from the bike.

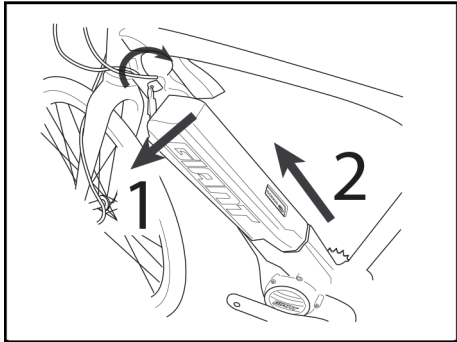

### Installing the EnergyPak:

- Reverse removal procedure to install the EnergyPak.
- Make sure the connector slots are aligned correctly at the bottom;
- Push the top of the EnergyPak and make sure the EnergyPak is secured properly (a 'click' can be noticed while doing so);
- Pull out the key.

## 3.1.6 EnergyPak Carrier

### Description

- A. EnergyPak
- B. Charging socket
- C. Energy level indicator

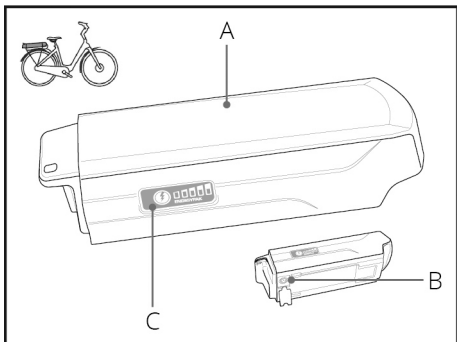

### Installation & removal



**NOTICE:** Always switch off the power first, before removing the EnergyPak.

### Removing the EnergyPak:

- Insert the key and unlock the EnergyPak
- Hold the grip and pull the EnergyPak backwards;
- Slide out the EnergyPak.

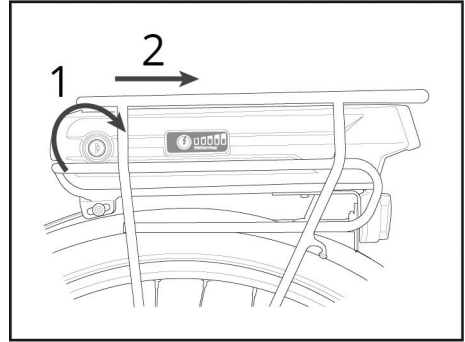

### Installing the EnergyPak:

- Reverse removal procedure to install the EnergyPak.
- Make sure the slots are aligned correctly at the bottom;
- Push the EnergyPak forward and make sure the EnergyPak is secured properly (a 'click' can be noticed while doing so);
- Pull out the key.

## 3.2 Charger



### CAUTION:

- Use only a suitable charger provided with the e-bike or provided by an authorized dealer.



### NOTICE:

- Not every charger type or version may be shown in this manual. Please refer to the support section of the website for more information on chargers.
- Exact technical specifications and other details can be found on the printed label on the charger.

## 3.2.1 Smart Charger

### Description

- A. AC socket
- B. Charger
- C. Button/LED
- D. LED
- E. Charge socket
- F. Adapter cable

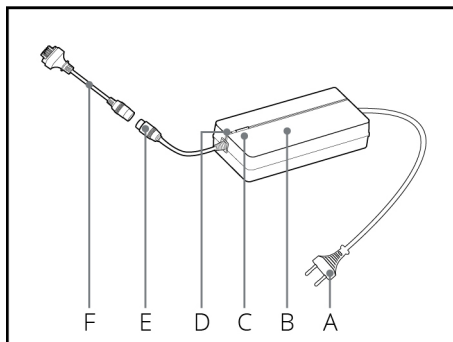

## LED Description

- A. LED
- B. Button/LED

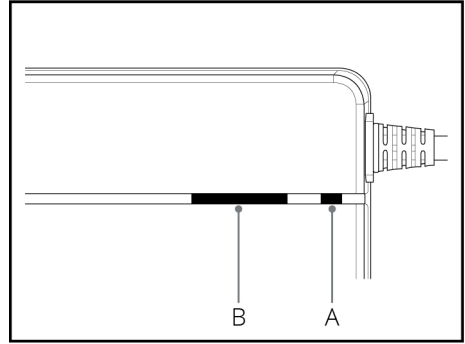

LED/ Button	Color	Behaviour	Status
A	RED > GREEN >	sequence	Power on self test (boot)
B	GREEN > RED > OFF		
A	RED	on	No battery connected
A	GREEN	blink (0.5 sec. interval)	Charging active
A	GREEN	blink (1.0 sec. interval)	Battery Temp. Time-out
A	GREEN	on	Charging completed
A	RED	blink (0.5~1.5 sec. pattern)	Charging issue
B	N/A	Push button	Activate storage charge (60%) mode
B	YELLOW	on	60% charge mode active



## 3.2.2 Smart Charger Compact

### Description

- A. AC socket
- B. Charger
- C. Button
- D. LED
- E. Charge socket
- F. Adapter cable

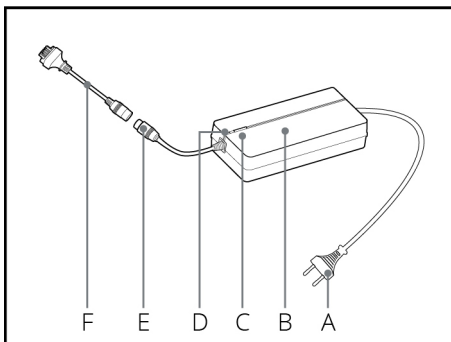

### LED Description

- A. LED
- B. Button

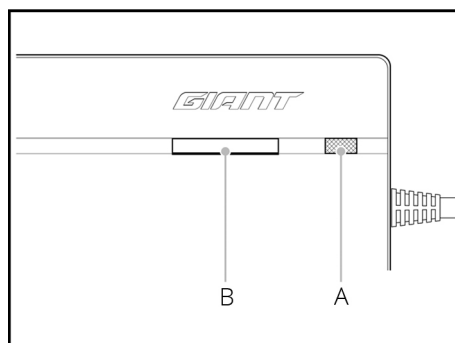

Mode	LED/ Button	Color	Behaviour	Status
ALL	A	RED > GREEN >	sequence	Power on self test (boot)
ALL	A	RED	on	No battery connected
Regular charge (100%)	A	GREEN	blink (0.5 sec. interval)	Charging active
Regular charge (100%)	A	GREEN	blink (1.0 sec. interval)	Battery Temp. Time-out
Regular charge (100%)	A	GREEN	on	Charging completed
	B		Push button	Activate storage charge (60%) mode
Storage charge (60%)	A	YELLOW	blink (0.5 sec. interval)	Charging active
Storage charge (60%)	A	YELLOW	blink (1.0 sec. interval)	Battery Temp. Time-out
Storage charge (60%)	A	YELLOW	on	Charging completed
ALL	A	RED	blink (0.5~1.5 sec. pattern)	Charging issue

### 3.2.3 Fast Charger

#### Description

- A. AC socket
- B. Charger
- C. LED
- D. Charge socket

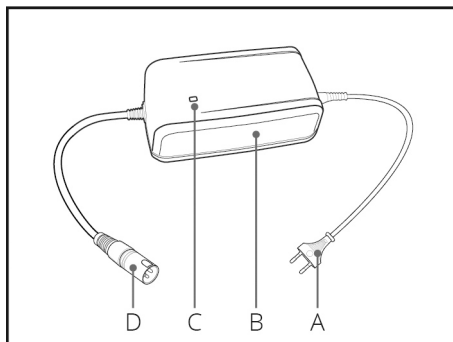

#### LED Description

- A. LED

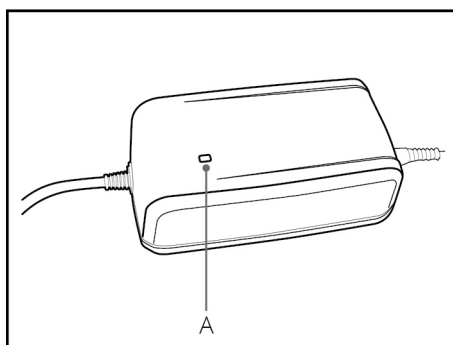

LED	Color	Behaviour	Status
A	RED	on	Charging active
A	RED	blink	Charging issue
A	GREEN	on	No battery / Battery full

## 3.2.4 Charging



### CAUTION:

- Always take care to align all connectors properly before connecting.
- Charge the EnergyPak battery at room temperature ( $\pm 20^{\circ}\text{C}/68^{\circ}\text{F}$ ).
- Charging below  $0^{\circ}\text{C}$  or above  $40^{\circ}\text{C}$  ( $32^{\circ}\text{F}\sim 104^{\circ}\text{F}$ ) can lead to insufficient charging and can have a negative impact on the battery life cycle.
- Make sure the bike is steady and standing firmly when charging the EnergyPak on the bike.
- Do not sit on the bike, move the bike or rotate the cranks while the charger is connected to the bike.

### Charging the EnergyPak

#### With the EnergyPak attached to the bike.

##### Start charging:

- Connect the charger to the charge port of the EnergyPak.
- Connect the charger to an AC outlet.
- The charging process starts.

##### Stop charging:

- Disconnect the charger from the AC outlet;
- Disconnect the charger from the EnergyPak.

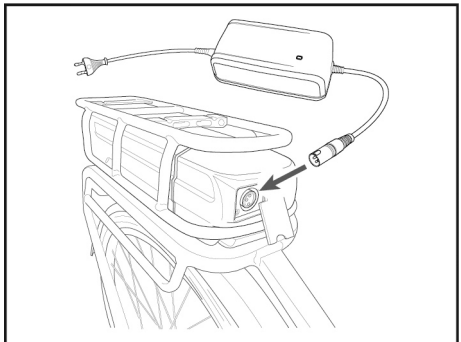
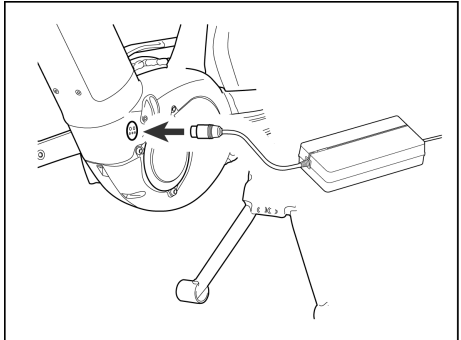

**With the EnergyPak removed from the bike.**

Start charging:

- Remove the EnergyPak from the bike.
- Connect the charger to the charge port of the EnergyPak.
- Connect the charger to an AC outlet.
- The charging process starts.

Stop charging:

- Disconnect the charger from the AC outlet;
- Disconnect the charger from the EnergyPak.
- Place the EnergyPak back into the bike.

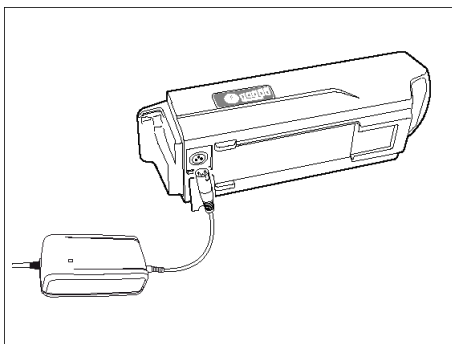
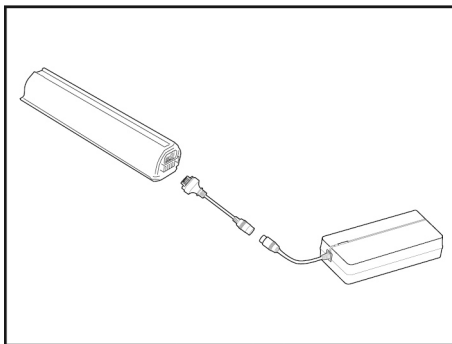

**INFO:**

- The LED(s) on the charger show the process status.
- The LED indicator on the EnergyPak shows current energy level.
- Charging can be stopped/interrupted at any time.



**NOTICE:** Disconnect the charger from the EnergyPak and AC outlet when the EnergyPak is fully charged.

## 3.2.5 Charging time

### Fast charger (4A) time table (110 V / 200-240 V)

EnergyPak capacity	300 Wh		400 Wh		500 Wh	
AC voltage	110 V	200-240 V	110 V	200-240 V	110 V	200-240 V
80% charge	2:20 h	1:45 h	3:00 h	2:00 h	3:40 h	2:45 h
100% charge	4:40 h	3:30 h	6:00 h	4:30 h	7:20 h	5:00 h

### Smart charger (4A) time table (110-240 V)

EnergyPak type	Smart 250	Smart Compact		Smart Integrated				Plus
Capacity	250 Wh	375 Wh	500 Wh	400 Wh	500 Wh	625 Wh	750 Wh	250 Wh
60% charge	1:20 h	1:20 h	2:00 h	1:50 h	2:00 h	2:30 h	2:50 h	1:20 h
80% charge	2:00 h	1:50 h	2:50 h	2:30 h	2:50 h	3:30 h	3:50 h	2:00 h
100% charge	3:30 h	3:40 h	5:10 h	3:55 h	5:10 h	5:50 h	6:40 h	3:30 h

### Smart charger (6A) time table (110-240 V)

EnergyPak type	Smart 250	Smart Compact		Smart Integrated				Plus
Capacity	250 Wh	375 Wh	500 Wh	400 Wh	500 Wh	625 Wh	750 Wh	250 Wh
60% charge	1:20 h	1:05 h	1:30 h	1:20 h	1:30 h	1:50 h	2:10 h	1:20 h
80% charge	2:00 h	1:35 h	2:10 h	2:00 h	2:10 h	2:35 h	2:55 h	2:00 h
100% charge	3:30 h	3:20 h	4:10 h	3:30 h	4:10 h	4:40 h	5:10 h	3:30 h

## 3.3 Controls

### 3.3.1 RideControl Ergo

The RideControl Ergo provides an ergonomic layout with easy-to-operate controls including power on/off, assist level, Smart Assist, Walk assist and lighting. Visual feedback comes from bright LED indicators or a screen like the RideDash EVO. Connect the RideControl app on your smartphone with your e-bike to add even more possibilities, which are ever expanding and improving with updates.

- A. Walk assist
- B. Assistance level down
- C. Assistance level up
- D. Power on/off
- E. Light/info
- F. Power assist indicator (5 LEDs)
- G. Light indicator (white) / Error indicator (red)
- H. Battery level indicator (5 LEDs)

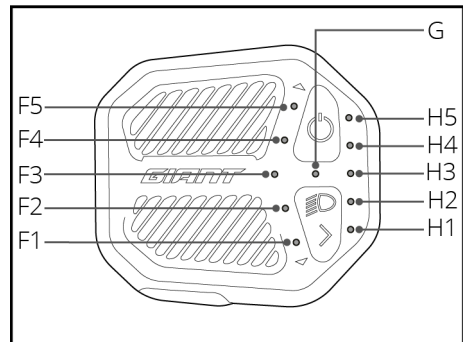
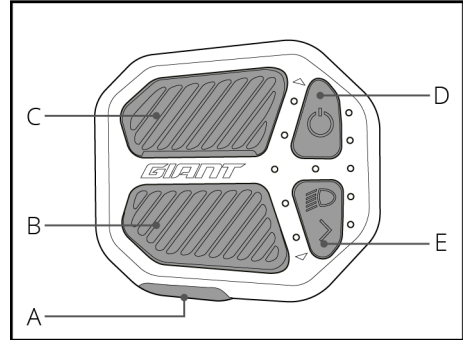

#### Powering on and off

- Press the 'Power on/off' button (D) to switch on the system.
- Press the 'Power on/off' button (D) for at least 1.5 seconds and release the button to switch off the system.
- Light indicator LED (G) will blink 3 times, indicating the bike is being switched off.

## Power Assist

### Smart Assist (AUTO):

The SyncDrive motor automatically adapts the power output to the circumstances to optimize ride comfort and range.

- Press and hold the 'Assistance level up' (C) or 'Assistance level down' button (B) for 2 seconds to activate Smart Assist.
- Power assist indication LED (F3) will be lit to indicate Smart Assist is active.
- If a RideDash is connected, it will show the Smart Assist level as 'AUTO' on the screen.
- Press the 'Assistance level up' (C) or 'Assistance level down' button (B) to return to manual assist level selection.



*INFO:* Smart Assist mode is not available on all models.

### Assist level 1-5:

Manually select the power assist level.

- Press the 'Assistance level up' (C) or 'Assistance level down' button (B) to change the assist level.
- Power assist indicator LEDs (F1 - F5) light to indicate the selected level.
  - F1 indicates the level with the lowest Power assist, but highest distance range (ECO level).
  - F5 indicates the level with strongest Power assist, but highest energy consumption (POWER level).

### Assist off:

For riding without Power Assist, but with indications / bicycle computer and light functions.

- Press the 'Assistance level down' button (B), until all Power Assist indicator LEDs (F) are off.
- Motor assist is switched off
- All other system functions remain available.

### Walk assist

The Walk assist function is to help you while walking with the bike. It works up to a speed of 6 km/h (4 mph). Walk assist is at its most powerful in the lowest gear, which means the smallest chain ring up front and the largest sprocket on the rear.



*INFO:* The Walk assist function is not available in some countries due to local regulations.

- Press the 'Walk assist' button (A) to set Walk assist standby.



- Power assist indicator LED's (F) light up in a back and forth sequence.
- Press the 'Assistance level up' button (C) within 3 seconds to engage Walk assist.
- Release the 'Assistance level up' button (C) to stop or pause Walk assist. Press again within 3 seconds to re-engage.
- Press any other button to return to normal riding mode immediately.



*INFO:* If no other action is performed within 3 seconds after pressing 'Walk assist' button (A), the system will return to normal riding mode.

## Lighting

- Press and hold the 'Light/info' button (E) for 2 seconds to switch the bike lights on or off.
- Light indicator (G) lights up when the light is switched on.
- On S-Pedelecs (high speed E-bikes) the bike lights cannot be switched off. The 'Light / Info' button (E) will switch between low beam and high beam.
- When switching on the bike light, the backlight of the RideDash EVO screen will be dimmed.

## Battery level indication

The remaining energy level of the EnergyPak is shown by the Battery level indicator LEDs (H1 - H5). Each LED represents 20% of the EnergyPak's capacity.

- When battery power is less than 10%, LED H1 changes from white to orange.
- When battery power is less than 3%, LED H1 blinks orange. The system will switch to lowest assist level.
- When battery power is less than 1%, the Power assist will shut down. The light system will be still functional for at least 2 hours.

## Info button

If a RideDash or other compatible bicycle computer is connected to the system the Light / Info button (E) can also be used to control various screen functions. The specific functionality depends on the connected device.

## System events

In case of a system event (malfunction), the RideControl will show an indication of the event. Assist power will stop on most system events. Lighting indicator (G) will flash red. One of the Power assist level indicators (F1 - F5) will start blinking as event indicator.

Event descriptions:

- F5: Heat issue
- F4: Not applicable
- F3: Speed sensor issue
- F2: Motor issues

- F1 : Battery issues

**Quick troubleshooting steps:**

1. Note which Power assist level indicator is blinking (F1 -F5).
2. Switch off the system.
3. Visually check for any obvious cause.
4. Solve any easy and obvious cause, if safely possible (e.g. reinstall incorrectly placed battery).
5. Switch the system back on.

If the issue is solved:

- Normal use may be continued.
- Schedule a service check at an authorized dealer.

If the issue returns:

- Repeat step 1-5.

If the issue persists:

- Stop riding.
- Contact authorized dealer for diagnosis and repairs.

### 3.3.2 RideControl Ergo 2

The RideControl Ergo 2 provides an ergonomic layout with easy-to-operate controls including power on/off, assist level, Smart Assist, Walk assist and lighting and USB charging port lets you recharge conveniently. Visual feedback comes from bright LED indicators or a screen like the RideDash EVO. Connect the RideControl app on your smartphone with your e-bike to add even more possibilities, which are ever expanding and improving with updates.

- A. Info
- B. Assistance level down
- C. Smart Assist (AUTO function)
- D. Assistance level up
- E. Power on /off
- F. USB-C port
- G. Light/screen backlight
- H. Walk assist
- I. Power assist indicator (5 LEDs)
- J. Light indicator (white) / Error indicator (red)
- K. Battery level indicator (5 LEDs)

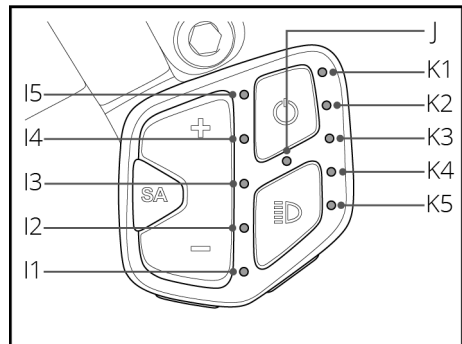
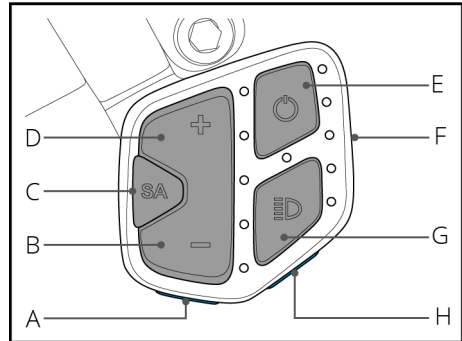

#### Powering on and off

- Press the 'Power on /off' button (E) to switch on the system.
- Press and hold the 'Power on /off' button (E) for at least 1.5 seconds and release the button to switch off the system.
- Light indicator LED (J) will blink 3 times, indicating the bike is being switched off.

#### Power Assist

##### Smart Assist (AUTO):

The SyncDrive motor automatically adapts the power output to the circumstances to optimize ride comfort and range.

- Press the 'Smart Assist' button (C) to activate Smart Assist.
- Power assist indication LED (I3) will be lit to indicate Smart Assist is active.

- If a RideDash is connected, it will show the Smart Assist level as 'AUTO' on the screen.
- Press the 'Assistance level up' (D) or 'Assistance level down' button (B) to return to manual assist level selection.



*INFO:* Smart Assist mode is not available on all models.

### **Assist level 1-5:**

Manually select the power assist level.

- Press the 'Assistance level up' (D) or 'Assistance level down' button (B) to change the assist level.
- Power assist indicator LEDs (I1 - I5) indicate the selected level.
  - I1 indicates the level with the lowest Power assist, but highest distance range (ECO level).
  - I5 indicates the level with strongest Power assist, but highest energy consumption (POWER level).

### **Assist off:**

For riding without Power Assist, but with indications / bicycle computer and light functions.

- Press 'Assistance level down' (B) button, until all Power assist indicator LEDs (I) are off.
- Motor assist is switched off
- All other system functions remain available.

### **Walk assist**

The Walk assist function is to help you while walking with the bike. It works up to a speed of 6 km/h (4 mph). Walk assist is at its most powerful in the lowest gear, which means the smallest chain ring up front and the largest sprocket on the rear.



*INFO:* The Walk assist function is not available in some countries due to local regulations.

- Press the 'Walk assist' button (H) to set Walk assist standby.
- Power assist indicator lights up in a back and forth sequence.
- Press the 'Power assist Up' button (D) within 3 seconds to engage Walk assist.
- Release the 'Power assist Up' button (D) to stop or pause Walk assist. Press again within 3 seconds to re-engage.
- Press any other button to return to normal riding mode immediately.



*INFO:* If no other action is performed within 3 seconds after pressing 'Walk assist' button (H), the system will return to normal riding mode.

## Lighting

- Press and hold the 'Light' button (G) for 2 seconds to switch the bike lights on or off.
- Light indicator (J) lights up when the light is switched on.
- On S-Pedelecs (high speed E-bikes) the bike lights cannot be switched off. The 'Light / Info' button (G) will switch between low beam and high beam.
- Press the 'Light' button (G) to switch RideDash EVO screen backlight to bright, dimmed or off.

## Battery level indication

The remaining energy level of the EnergyPak is shown by the Battery indicator LEDs (K1 - K5). Each LED represents 20% of the EnergyPak's capacity.

- When battery power is less than 10%, LED K5 changes from white to orange.
- When battery power is less than 3%, LED K5 blinks orange. The system will switch to lowest assist level.
- When battery power is less than 1%, the Power assist will shut down. The light system will be still functional for at least 2 hours.

## Info button

The 'Info' button (A) is used to control various screen functions if a RideDash or other compatible bicycle computer is connected to the system. The specific functionality depends on the connected device.

## USB-C port

The USB-C port (F) can be used to power or charge an external device like a smartphone, bike light or bicycle computer.

- To access the USB-C port, use a fingernail to lift the cover. Use the appropriate cable (not included) for your device to connect it.
- The port is only a power outlet (5 V / 1.5 A). It cannot be used for data transfer.



### CAUTION:

- Do not use the USB-C port in wet or moist conditions.
- Make sure no liquids, mud or dirt can enter the USB-C port.
- Always close the USB port cover properly when the USB-C port is not in use.

## System events

In case of a system event (malfunction), the RideControl will show an indication of the event. Assist power will stop on most system events. Lighting indicator (J) will flash red. One of the Power Assist indicator LEDs (I1 - I5) will start blinking as event indicator.

Event descriptions:

- I5: Heat issue

- I4: Not applicable
- I3: Speed sensor issue
- I2: Motor issues
- I1 : Battery issues

**Quick troubleshooting steps:**

1. Note which Power assist indicator LED is blinking (I1 -I5).
2. Switch off the system.
3. Visually check for any obvious cause.
4. Solve any easy and obvious cause, if safely possible (e.g. reinstall incorrectly placed battery).
5. Switch the system back on.

If the issue is solved:

- Normal use may be continued.
- Schedule a service check at an authorized dealer.

If the issue returns:

- Repeat step 1-5.

If the issue persists:

- Stop riding.
- Contact authorized dealer for diagnosis and repairs.

### 3.3.3 RideControl Ergo 3

This updated control system features clean buttons that can be integrated with the handlebar grips.

The RideControl Ergo 3 on the left handlebar is used to control the Assistance levels and the Walk assist mode.

The optional second RideControl Ergo 3 is installed on the right handlebar grip and can be used to control functions like the light, Smart Assist or the display functions of a RideDash EVO,. The functions can be set using the RideControl App (v1.8.1 and higher).



**INFO:** RideControl Ergo 3 should be installed together with RideControl Go.

- A. Assistance level up
- B. Walk assist
- C. Assistance level down
- D. Light
- E. Smart Assist
- F. Info

Left control

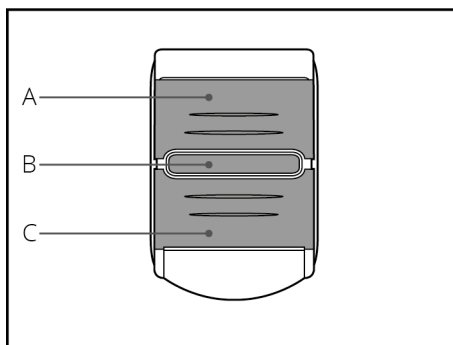

Right control (optional)

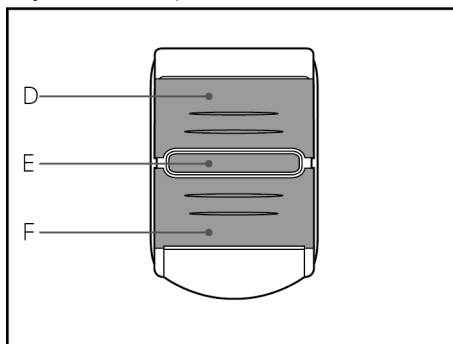

## Power Assist

### Smart Assist (AUTO):

The SyncDrive motor automatically adapts the power output to the circumstances to optimize ride comfort and range.

- Press and hold the 'Smart Assist' button (E) or 'Assistance level up' button (A) or 'Assistance level down' button (C) for 3 seconds to activate Smart Assist.



*INFO:* Smart Assist mode is not available on all models.

### Assist level 1-5:

Manually select the assist level.

- Press the 'Assistance level up' (A) or 'Assistance level down' (C) to change the assist level.

### Walk assist

The Walk assist function is to help you walk with the bike. It works up to a speed of 6 km/h (4 mph). Walk assist is at its most powerful in the lowest gear, which means the smallest chain ring up front and the largest sprocket on the rear.



*INFO:* The Walk assist function is not available in some countries due to local regulations.

- Press the 'Walk assist' button (B) to set Walk assist standby. LED B1~B5 on the RideControl GO blink white.
- Press and hold the 'Assistance level up' button (A) within 3 seconds to engage Walk assist.
- Release the 'Assistance level up' button (A) to stop or pause. Press and hold the 'Assistance level up' button (A) again within 3 seconds to re-engage.
- Press any other button on the RideControl Ergo 3 to return to normal riding mode immediately.



*INFO:* If no other action is performed within 3 seconds after pressing 'Walk assist' button, the system will return to normal riding mode.



## Lighting

- Press the 'Light' button (D) to switch the bike light On or Off.
- When switching on the bike light, the backlight of the RideDash EVO screen will be dimmed.
- On S-Pedelecs (high speed E-bikes), the bike lights cannot be switched off. The 'Light' button (G) will switch between low beam and high beam.

## Information

The 'Info' button (F) is used to control various screen functions of a 'RideDash', 'RideControl Dash or other compatible bicycle computer that is connected to the system. The specific functionalities depend on the connected device.

### 3.3.4 RideControl Dash

The RideControl Dash is a remote with integrated colour display screen that shows extensive bike and ride information from the EnergyPak(s), SyncDrive motor, sensors, lights and other connected e-components. Ergonomically placed at the left handlebar grip, it offers many features of the RideControl Ergo remotes and the RideDash EVO, into a single compact unit.

- A. Assistance level down
  - B. Assistance level up
  - C. Info
  - D. Walk assist
  - E. Power on/off
  - F. Light/screen backlight
  - G. USB-C port
  - H. Status bar
  - I. Data field
  - J. Power assist level indicator
1. Wireless connection
  2. Light status
  3. Phone notification
  4. Service
  5. Battery status

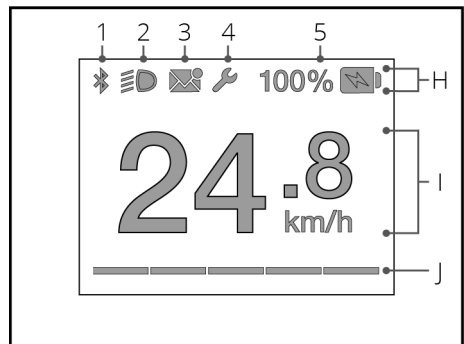
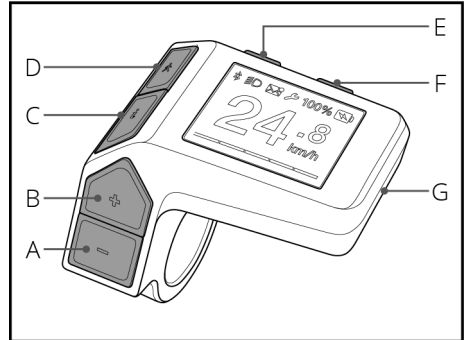

**INFO:** The Walk assist function is not available in some countries due to local regulations.

#### Powering on and off

- Press the 'Power on/off' button (E) to switch on the system.
- Press the 'Power on/off' button (E) for 2 seconds to switch off the system.

#### Power Assist

##### Smart Assist (AUTO):

In Smart Assist (AUTO) mode, the SyncDrive motor automatically adapts the power output to the circumstances to optimize ride comfort and range.

- Press the 'Assistance level up' button (B) and 'Assistance level down' button (A) simultaneously for 2 seconds to activate Smart Assist.

### Manually select the assist level:

- Press the 'Assistance level up' (B) or 'Assistance level down' button (A) to change the assist level.
- Power assist level indicator (J) indicate the selected level.

The screen shows the new assist level name and estimated remaining riding range for 2 seconds. Then the riding screen will return with an updated level indicator.

### Screen

#### Status bar:

Status bar (H) always shows the battery status (5). Other icons (1-4) will appear when that function is active.

1. **Wireless connection:** Indicates an active wireless connection between the bike and a smartphone with the RideControl app.
2. **Light status:** The light icon indicates that the bike lights are switched on.
3. **Notification:** Indicates that there are new or unread messages on a smartphone. Only via the RideControl app.
4. **Service indicator:** The service indicator (wrench icon) appears when periodic technical maintenance is due or when a system event (malfunction) has occurred.
5. **Battery status indicator:** The battery status indicator shows the current EnergyPak charge level from 100% to 0%.
  - When battery power is less than 3%, the battery icon starts blinking. The system will switch to lowest assist level.
  - When battery power is less than 1%, the battery icon is blinking. Power Assist will shut down. The light system will be still functional for at least 2 hours.



*INFO:* Some RideControl app functions and features mentioned in this manual may not be available at this time. Compatibility and available features may also vary depending on app version, e-bike model, component hardware/firmware version, smartphone specifications, operating system, etc.

### Data field (I):

Data field (I) is a single data field to display specific information.

Data field options:

- SPEED: Current riding speed (default).
- RANGE: Estimated remaining riding range on current assist level.
- ODO: Total riding distance since first use.
- DISTANCE: Riding distance since last reset.
- TRIP TIME: Riding time since last reset.
- AVG SPEED: Average speed since last reset.
- MAX SPEED: Maximum speed since last reset.
- CADENCE: Current pedaling speed in rpm (rotations per minute).



*INFO:* Various circumstances during the ride, like terrain profile or wind strength and direction, may affect the actual range.

- Press the 'Info' button (C) to change to a different data field. The screen will display the description of the new field for 2 seconds and switch to the new field.

### Power assist level indicator:

The Power assist level indicator (J) visually represents the currently selected assist level as a row of 5 bars, that can vary in color.

Assist level options:

- OFF
- ECO
- TOUR
- ACTIVE
- SPORT
- POWER
- SMART ASSIST (AUTO)



*INFO:* Assist levels availability and power ratio per level depend on SyncDrive motor type and factory system settings.

### Walk assist

The Walk assist function is to help you while walking with the bike. Walk assist works up to a speed of 6 km/h (4mph) and is at its most powerful in the lowest (easiest) gear.

- Press the 'Walk assist' button (D) to set walk assist standby.
- Press the 'Assistance level up' button (B) within 3 seconds to engage Walk assist.
- Release the 'Assistance level up' button (D) to stop or pause Walk assist. Press again within 3 seconds to re-engage.

- Press any other button to return to normal riding mode immediately.



**INFO:** If no other action is performed within 3 seconds after pressing 'Walk assist' button (D), the system will return to normal riding mode.

### Lighting / screen brightness

- Press and hold the 'Light / Info' button (F) for 2 seconds to switch the bike lights on or off.
- Light indicator (2) lights up when the light is switched on.
- Press the 'Light button' (F) repeatedly to change the brightness of the screen between low, medium or high.

### USB-C port

The USB-C port (G) can be used to power or charge (5 V / 1.5 A) an external device like a smartphone, bicycle light or bicycle computer.

- To access the USB port, pull the corner and lift the cover.
- Connect your device using an appropriate cable (not included).
- After use close the USB port cover properly.



### CAUTION:

- The USB port is only a power outlet . It cannot be used for data transfer.
- Do not use the USB port in wet or moist conditions.
- Make sure no liquids, mud or dirt can enter the USB port.

### Settings

#### Changing display units (metric/imperial):

- Press and hold the 'Info' button (C) for 5 seconds.

#### Resetting sub data fields:

- To clear DIST, TRIP, AVG SPD:
  - Press and hold the 'Assistance level up' (B) and 'Assistance level down' (A) buttons simultaneously for 3 seconds.
- To clear MAX SPD:
  - Scroll to MAX SPD data field.
  - Press and hold the 'Assistance level up' (B) and 'Assistance level down' (A) buttons simultaneously for 3 seconds.

## System events

A system event warning screen shows when a malfunction occurs:

- A warning screen is displayed for 2 seconds.
- An event description is displayed for 5 seconds.
- The riding screen returns after the warning screen, showing the service indicator in the status bar.

Quick troubleshooting steps:

1. Make a note of the event description.
2. Switch off the system.
3. Visually check for any obvious cause.
4. Solve any easy and obvious cause, if safely possible (e.g. reinstall incorrectly placed battery).

Switch the system back on. If the issue is solved:

- Normal use may be continued.
- Schedule a service check at an authorized dealer.

If the issue returns, repeat step 1-4.

If the issue persists:

- Quit riding.
- Contact authorized dealer for diagnose and repairs.

### 3.3.5 RideControl GO

RideControl Go is the multipurpose control button integrated into the top tube. It features an on/off button and colored LED lights to indicate support mode and battery level.

- A. Power on/of button / multicolor LED
- B. Power assist indicators (5 multicolor LEDs)
- C. Battery level indicators (5 multicolor LEDs)

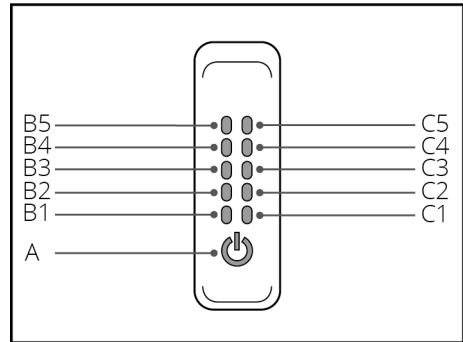

*INFO:* It is possible to use the RideControl Go in combination with additional RideControl Ergo types and RideDash screens. Contact your authorized dealer or visit the Giant website for more information.

#### Powering on and off

- Press the 'Power on/off' button (A) to switch on the system.
- Upon power on, all LED indicators will first light up white.
- After 2 seconds, the indicators will show the default Power assist level and Battery level.
- Press the 'Power on/off' button (A) for 3 seconds and release the button to switch off the system.
- Upon power off, all LED indicators will light up and blink white once and the system powers off.



*INFO:* For Shimano motors, hold the 'Power on/off' button (A) for 0.5 seconds to switch on the system.

#### Power assist level

##### Smart Assist function (AUTO):

The SyncDrive motor automatically adapts the power output to the circumstances to optimize ride comfort and range.

- Press the 'Power on/off' button (A) twice to activate Smart Assist.
- Power assist indication LED B3 will light blue to indicate Smart Assist is active.
- If a RideDash is connected, it will show the Smart Assist level as 'AUTO' on the screen.

- Press the 'Power on/off' button (A) to deactivate Smart Assist and return to the manual assist level selection.



*INFO:* Smart Assist mode is not available on all models.

### Assist level 1-5:

#### Manually select the power assist level.

- Press the 'Power on/off' button (A) to change the assist level.
- Repeat until the desired assist level is selected.

Power assist indicator LEDs B1 to B5 will indicate the selected level as follows:

Assist level	LED on	LED color
POWER	1+2+3+4+5	Red
SPORT	1+2+3+4	Orange
ACTIVE	1+2+3	Yellow
TOUR	1+2	Green
ECO	1	Green
SMART ASSIST (AUTO)	3	Blue
OFF	All off	Off

POWER level: the level with strongest Power Assist, but highest energy consumption.

ECO level: the level with the lowest Power Assist, but highest distance range.



*INFO:* Assist level options depend on bike model

### Assist off:

For riding without Power Assist, but with indications / bicycle computer and light functions.

- Press the 'Power on/off' button (A) until all Power assist indicator LEDs (B) are off.
- Motor assist is switched off.
- All other system functions remain available.

### Battery Level

The remaining energy level of the EnergyPak is shown by the Battery level indicator LEDs (C1-C5).



Battery level	LED on	LED color
80~100%	1+2+3+4+5	White
60~79%	1+2+3+4	White
40~59%	1+2+3	White
20~39%	1+2	White
10~29%	1	White
4~9%	1	Orange
0~3%	1	Orange blinking



**NOTICE:** When battery power is less than 1%, the Power Assist will switch to off mode. The light system will be still functional for at least 2 hours

### System events

In case of a system event (malfunction), the RideControl Go will show an indication of the event.

- All assist level indicators LEDs blink white 3 times.
- Power assist level indicator LED (B1 -B5) starts blinking indicating the event.

Event	LED on	LED color
EnergyPak error	1	Red blinking
SyncDrive error	2	Red blinking
Speed sensor error	3	Red blinking
Smart Gateway/Remote/ Display error	4	Red blinking
Motor overheated	5	Red blinking

### Quick troubleshooting steps:

1. Note which Power assist level indicator LED is blinking (B1 -B5).
2. Switch off the system.
3. Visually check for any obvious cause.
4. Solve any easy and obvious cause, if safely possible (e.g. reinstall incorrectly placed battery).
5. Switch the system back on.

If the issue is solved:

- Normal use may be continued.

- Schedule a service check at an authorized dealer.

If the issue returns:

- Repeat step 1-5.

If the issue persists:

- Stop riding.
- Contact authorized dealer for diagnosis and repairs.

### 3.3.6 RideDash EVO

The RideDash EVO gives the rider extensive bike and ride information on a beautiful, large colour screen placed in the centre of the handlebar. Operated by the RideControl Ergo series, it shows clear and large indications of items like speed, distance, battery status, remaining range, and other useful information.

- A. Status bar
  - B. Data field
  - C. Assistance level indicator
  - D. Sub data fields
  - E. Selected page indicator
1. Wireless connection
  2. Light status
  3. Phone notification
  4. Service
  5. Battery status

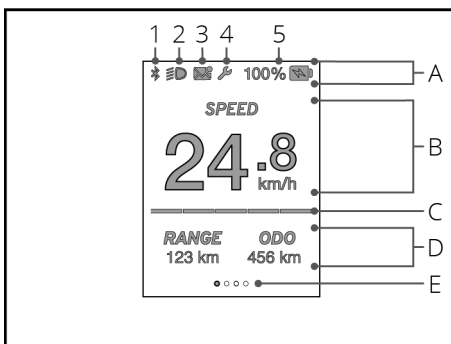

#### Status bar

Status bar (A) always shows the battery status (5). Other icons (1-4) will appear when that function is active.

1. **Wireless connection:** Indicates an active wireless connection between the bike and a smartphone with the RideControl app
2. **Light status:** The light icon indicates that the bike lights are switched on.
3. **Notification:** Indicates that there are new or unread messages on a smartphone. Only via the RideControl app.
4. **Service indicator:** The service indicator (wrench icon) appears when periodic technical maintenance is due or when a system event (malfunction) has occurred.
5. **Battery status indicator:** The battery status indicator shows the current EnergyPak charge level from 100% to 0%.
  - When battery power is less than 3%, the battery icon starts blinking. The system will switch to lowest assist level.
  - When battery power is less than 1%, the battery icon is blinking. Power Assist will shut down. The light system will be still functional for at least 2 hours.



*INFO:* Some RideControl app functions and features mentioned in this manual may not be available at this time. Compatibility and available features may also vary depending on app version, e-bike model, component hardware/firmware version, smartphone specifications, operating system, etc.

#### Main data field

Main data field (B) shows the current speed.

## Sub data field

Sub data field (D) shows detailed information divided over four pages

Page 1 (Default):

- RANGE: Estimated remaining riding range on current assist level.\*
- ODO: Total riding distance since first use.

Page 2:

- DIST: Riding distance since last reset.
- TRIP: Riding time since last reset.

Page 3:

- AVG SPD: Average speed since last reset.
- MAX SPD: Maximum speed since last reset.

Page 4:

- CAD: Current pedalling speed in rpm (rotations per minute).
- RANGE: Estimated remaining riding range on current assist level.\*

\*The range is an estimated number. Various circumstances during the ride, like terrain profile or wind strength and direction, may affect the actual range.

### To select a page

On all RideControl Ergo controls:

- Press the 'Info' button until the desired page is shown.
- Release the 'Info' button.

## Page indicator

The page indicator (E) displays the number of Sub data pages and highlights the currently selected page.

## Assist level indicator

The Assist Level indicator (C) visually represents the currently selected assist level as a row of 5 bars, that can vary in colour.

Assist level options\*:

- OFF
- ECO
- TOUR
- ACTIVE
- SPORT
- POWER
- SMART ASSIST (AUTO)

\*Assist levels availability and power ratio per level depend on SyncDrive motor type and factory system settings.

The screen shows the new assist level name and estimated remaining riding range for 2 seconds. Then the riding screen will return with an updated level indicator.

## Settings

### Changing display units between metric and /imperial.

On all RideControl Ergo controls:

- Press and hold the 'Info' button for 5 seconds.

### Resetting sub data fields.

On all RideControl Ergo controls:

- Clear DIST, TRIP, AVG SPD:
  - Press and hold the 'Power assist up' and 'Power assist down' buttons simultaneously for 3 seconds.
- Clear MAX SPD:
  - Scroll to MAX SPD data field.
  - Press and hold the 'Power assist up' and 'Power assist down' buttons simultaneously for 3 seconds.

### Changing the screen brightness to low, medium or high.

On RideControl Ergo:

- Press and hold the 'Walk assist' button for 2 seconds to change to the next brightness level.
- Release button after 2 seconds.

On RideControl Ergo 2:

- Press the 'Light' button to change to the next brightness level.

On RideControl Ergo 3:

- Press the 'Light' button to change to the next brightness level.

## System events

A system event warning screen shows when a malfunction occurs:

- A warning screen is displayed for 2 seconds.
- An event description is displayed for 5 seconds.
- The riding screen returns after the warning screen, showing the service indicator in the status bar.

Quick troubleshooting steps:

1. Make a note of the event description.
2. Switch off the system.

3. Visually check for any obvious cause.
4. Solve any easy and obvious cause, if safely possible (e.g. reinstall incorrectly placed battery).

Switch the system back on. If the issue is solved:

- Normal use may be continued.
- Schedule a service check at an authorized dealer.

If the issue returns, repeat step 1-4.

If the issue persists:

- Quit riding.
- Contact authorized dealer for diagnose and repairs.

### 3.3.7 STI Lever

Button functions can be set using the RideControl app. The STI lever can only be used on specific models.

#### STI Lever functions

- A. Assist up
- B. Assist down
- C. Rear shift up

Left STI Lever

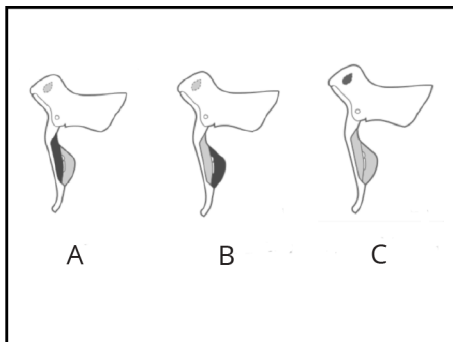

- A. Rear shift down
- B. Rear shift up
- C. Rear shift down

Right STI Lever

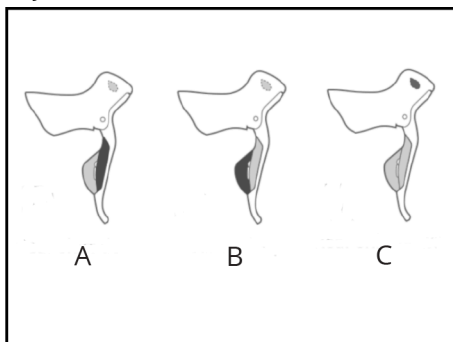

## 3.4 Keys

Several models come standard with two identical keys that fit the battery lock and/or bike lock. Without 1 of the keys, the lock(s) cannot be unlocked.



#### NOTICE:

- Always bring the key when visiting the dealer for maintenance or repairs.
- Store the key and key number tag together with the bike's frame number and other documents.
- It is recommended to have a qualified locksmith make an extra spare copy of the original key and store it separately.

## 3.5 Riding range

The range on one charge strongly depends on several circumstances, such as (but not limited to):

- The total vehicle weight including the rider, passengers and cargo loaded onto the bike.
- Weather conditions, such as ambient temperature and wind.
- Road conditions, such as elevation and road surface.
- Bike conditions, such as tire pressure and maintenance level.
- Amount of charge and discharge cycles.
- Age and condition of the EnergyPak.
- Bike usage, such as acceleration and shifting.
- Assist level(s) used.
- User assist level settings (by smartphone app).



## 4 Transport & Storage

### Transport

**CAUTION:**

- Any removable (electronic) parts, such as the charger and EnergyPak, should always be removed from the e-bike before transport.
- Always follow the instructions provided by the manufacturer(s) of the vehicle and/or bicycle carrier being used for transporting the e-bike.

**NOTICE:**

- Avoid transporting the e-bike in bad weather conditions when possible.
- Properly cover any exposed electronic parts during transport when transport in bad weather conditions can not be avoided.
- High speeds combined with wind and rain could cause moisture to be pressured into the electronic parts, which can lead to temporary malfunctions or permanent defects.
- If a malfunction occurs after transport in such conditions, remove the EnergyPak and allow all parts to dry by air when the destination is reached.

### E-bike storage

Store the e-bike in a location where it is protected from the elements whenever possible.

**NOTICE:**

- Snow, rain, road salts and acids can cause certain parts of the e-bike to corrode or deteriorate.
- Ultraviolet light from the sun can fade the paint and can cause rubber or plastic parts to become porous or to crack.
- Exposure to excessively high or low temperatures during storage can cause temporary malfunctions or even permanent defects.

## Battery storage

Disconnect and remove the EnergyPak from the bike for long term storage.



### **CAUTION:**

- Store the EnergyPak in a dry, safe location.
- Store the EnergyPak at a temperature between -20°C and 20°C (-4°F ~ 68°F).



### **NOTICE:**

- Storage at temperatures above 20°C (68°F) can decrease battery health and overall service life.
- Store the EnergyPak at about 60% charge level.
- Check the EnergyPak charge level monthly during longer storage periods.
- Recharge the EnergyPak when charge level has dropped below 60%.
- Charge the EnergyPak to 60% at least once in every 3 months.
- Improper storage and/or long term neglect of the EnergyPak can cause decreased capacity and defects, and may void the factory warranty.

# 5 Maintenance

Regular maintenance and cleaning are essential for optimal performance and safety.



*INFO:* Make sure to also read the information on maintenance on the website and in general bike owner's manual.

## Cleaning

Use a soft cloth or brush, optionally with a minimal amount of a neutral cleaning solution, to wipe dirt off. Wipe dry with a clean soft cloth afterwards.



### CAUTION:

- Do not use high-pressure water or air hoses for cleaning. It can force water into (sealed) electric components, which may cause malfunctions and defects.
- Do not wash the E-bike components with excessive water. If water reaches internal electrical parts, it may cause malfunctions and other problems.



### NOTICE:

- Do not use non-neutral cleaning solutions to wash the components. Non-neutral solutions may cause materials to deteriorate, change colour, distort, scratch etc.

## Drivetrain



### WARNING:

- Always remove the battery when checking the chain tension. Placing your hands (or other body parts) anywhere on the drivetrain while the system is still powered, could result in sudden activation of the motor.



### CAUTION:

- Any adjustments or replacements should only be performed with proper tools by a trained mechanic.
- Ask your dealer for more information and support on your E-bike's technical maintenance.

## Chain tension

Some models have an internal gear hub in the rear wheel. It may also have an automatic chain-tensioner that maintains proper chain tension.

If there is too much slack on the chain, the tension may have to be adjusted, or the chain may have worn out and needs to be replaced.

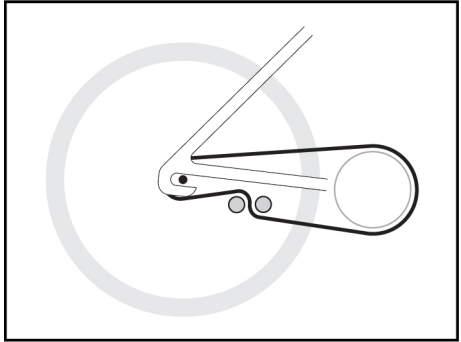

## How to check chain tension:

To check the chain tension, block crankarm rotation and hold the chain in the middle section between the front and rear sprockets.

- Move the chain up and down to check the slack on the chain;
- There should be between 10-15 mm of vertical movement;
- If the movement is significantly more or less, contact your dealer for technical service.

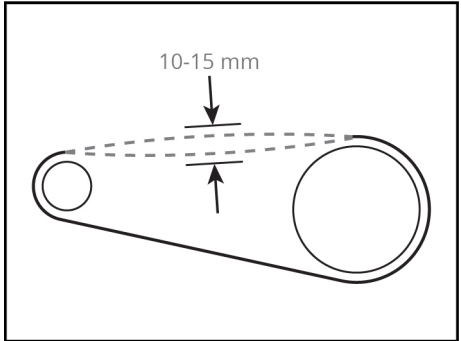

## Belt Drive:

Read the belt drive manufacturer's operating instructions provided with the E-bike for technical specifications and requirements.

All models with belt drive have sliding rear drop-outs and tension adjustment screws to adjust the belt tension. The adjustment procedure for a belt drive is the same as for a chain.

## 6 Disposal



According to directive 2006/66/EC of the European Parliament, defective or used batteries, battery packs or single cells must be collected separately and disposed of in an environmentally friendly manner.

Used cells and batteries are recyclable economic goods. In accordance with the marking showing a crossed-out waste bin, these batteries may not be disposed of as domestic waste.



### NOTICE:

- Used batteries must be treated as hazardous waste.
- Batteries must be disposed of in accordance with the relevant national environmental protection regulations.
- Return batteries to a recycling facility, or an authorized Giant dealer.
- In case of uncertainty contact Giant customer service department.

# 7 Legal documentation

## 7.1 Warranty

Giant/Liv/Momentum warrants for the original owner only the frame, rigid fork, or original component parts of each new Giant/Liv/Momentum brand bicycle to be free from defects in material and workmanship for the following specified periods:

Warranty of two years for electronic equipment such as:

- RideControl display & buttons
- SyncDrive motor
- EnergyPak battery;
  - for 60% of its original nominal capacity at a maximum of 600 charges.
- Wiring

The maximum permissible total weight (bicycle, rider and luggage) for our E-bikes is 156 kg (344 lbs).

For all other parts and components we refer to the general user manual that is delivered with this e-bike as well. That user manual is leading in case of any issues. The information below and in *Exclusions* on page 53 is only for reference.

### REQUIRED ASSEMBLY WHEN PURCHASED.

This warranty applies only to bicycles and frame sets purchased new from an Authorized Giant/Liv/Momentum Dealer and assembled by that dealer at the time of purchase.

### LIMITED REMEDY

Unless otherwise provided, the sole remedy under the above warranty, or any implied warranty, is limited to the replacement of defective parts with those of equal or greater value at the sole discretion of Giant/Liv/Momentum. This warranty extends from the date of purchase, applies only to the original owner, and is not transferable. In no event shall Giant/Liv/Momentum be responsible for any direct, incidental or consequential damages, including, without limitation, damages for personal injury, property damage, or economic losses, whether based on contract, warranty, negligence, product liability, or any other theory.

Giant/Liv/Momentum makes no other warranties, express or implied. All implied warranties, including the warranties of merchantability and fitness for a particular purpose are limited in duration to that of the express warranties stated above. Any claim against this warranty must be made through an Authorized Giant/Liv/Momentum or distributor. The purchase receipt or other proof of the date of purchase is required before a warranty claim may be processed.

Claims made outside the country of purchase may be subject to fees and additional restrictions. Warranty duration and detail may differ by frame type and/or by country. This warranty gives you specific legal rights, and you may also have other rights which may vary from place to place. This warranty does not affect your statutory rights.

## 7.2 Exclusions

Normal wear and tear on parts such as tires, chains, brakes, cables and gearwheels in situations where there are no assembly or material defects.

- Bicycles serviced by other than an Authorized Giant/Liv/Momentum dealer.
- Modifications from the original condition.
- Use of the bicycle for abnormal, competition and/or commercial activities or for purposes other than those for which the bicycle was designed.
- Damage caused by failing to follow the user manual.
- Paint finish and decal damage resulting from taking part in competitions, jumping, downhill and/or training for such activities or events or as a result of exposing the bike to, or riding the bike in, severe conditions or climates.
- Labour charges for part replacement or changeover.

Except as is provided by this warranty and subject to all additional warranties Giant/Liv/Momentum and its employees and agents shall not be liable for any loss or damage whatsoever (including incidental and consequential loss or damage caused by negligence or default) arising from or concerning any Giant/Liv/Momentum bicycle.

## 7.3 Conformity



Hybrid power bicycles with a maximum support speed of 45km/h fulfil the requirements of EU Directive 168/2013/EC for L1e-B category vehicles.

Hybrid power bicycles with a maximum support speed of 25km/h fulfil the requirements of EU Machinery Directive 2006/42/EC.

The A-weighted emission sound pressure level at the rider's ears is less than 70 dB(A).

These bicycles also comply with the following non-harmonized standards:

- Bicycle standard: ISO 4210-2
- Electric bicycles: EN 15194

The declaration of conformity for your specific e-bike can be found as an inlay in this user manual.

## 7.4 Disclaimer

Do not tamper with your bicycle. Tampering is removing or replacing any original equipment or modifying your bicycle in anyway that may change its design and/or operation. Such changes may seriously impair the handling, stability and other aspects of the bicycle, making it unsafe to ride. Tampering can void the warranty and render your bike not in compliance with the applicable laws and regulations. To ensure safety, quality and reliability, use only original parts or Giant/Liv/Momentum authorized replacements for repair and replacement. Giant/Liv/Momentum is not responsible for any direct, incidental or consequential damages, including, without limitation, damages for personal injury, property damage, or economic losses due to tampering.

## 7.5 FCC

This device complies with part 15 of the FCC Rules. Operation is subject to the following two conditions:

1. This device may not cause harmful interference, and
2. This device must accept any interference received, including interference that may cause undesired operation.

Please note that changes or modifications not expressly approved by the party responsible for compliance could void the user's authority to operate the equipment.



*INFO:* This equipment has been tested and found to comply with the limits for a Class B digital device, pursuant to part 15 of the FCC Rules. These limits are designed to provide reasonable protection against harmful interference in a residential installation. This equipment generates, uses and can radiate radio frequency energy and, if not installed and used in accordance with the instructions, may cause harmful interference to radio communications. However, there is no guarantee that interference will not occur in a particular installation. If this equipment does cause harmful interference to radio or television reception, which can be determined by turning the equipment off and on, the user is encouraged to try to correct the interference by one or more of the following measures:

- Reorient or relocate the receiving antenna.
- Increase the separation between the equipment and receiver.
- Connect the equipment into an outlet on a circuit different from that to which the receiver is connected.
- Consult the dealer or an experienced radio/TV technician for help.

This equipment complies with radio frequency exposure limits set forth by the FCC for an uncontrolled environment.

This equipment should be installed and operated with a minimum distance of 5mm between the device and the user or bystanders.

This device must not be co-located or operating in conjunction with any other antenna or transmitter.

## 7.6 IC

This device complies with Industry Canada's licence-exempt RSSs. Operation is subject to the following two conditions:

1. This device may not cause interference;
2. This device must accept any interference, including interference that may cause undesired operation of the device.

This equipment complies with radio frequency exposure limits set forth by the Innovation, Science and Economic Development Canada for an uncontrolled environment.



This equipment should be installed and operated with a minimum distance of 5 mm between the device and the user or bystanders.

This device must not be co-located or operating in conjunction with any other antenna or transmitter.

