

GIANT CONTACT SWITCH CORE

USER MANUAL



CONTENTS

1. INTRODUCTION	2
2. PARTS LIST	3
3. SPECIFICATIONS.....	4
4. REMOTE LEVER OPTIONS.....	5
5. INSTALLATION.....	6
6. OPERATION	8
7. CARE OF USE AND TROUBLESHOOT.....	8
8. GIANT LIMITED WARRANTY	9

1. INTRODUCTION

Congratulations on the purchase of your new GIANT CONTACT SWITCH CORE. This product features robust construction, and durable spring-activated internals for long-lasting, reliable action.

The design has brought down to its pure utility – *high position* for riding efficiency; *low position* for challenging technical sessions. No fuss on in-between positions.

100mm and 125mm travel options to suit most riders' fitting demands.

Simple and affordable, GIANT CONTACT SWITCH CORE helps you tackle your local trail like a pro.

⚠ CAUTION

Please read the instructions thoroughly before installing and using this seatpost. Failure to follow the instructions may result in serious injury or death.

1. Adjusting saddle height while moving can cause the loss of control.
2. Never ride with a CONTACT SWITCH CORE seatpost that is modified. Any modifications will void the warranty.
3. Loose, over-tightened, damaged, or worn parts may cause unexpected malfunction. Periodically check the seatpost for wear or damage. If there are any indications of wear, cracks, or dents shown on the seatpost or any of its parts, stop using the seatpost immediately and find an authorized GIANT dealer for inspection, repair or replacement.
4. Please check that all bolts on the CONTACT SWITCH CORE seatpost have been properly fastened within the recommended torque settings before you ride.
5. Over-tightening the seatpost clamp will affect the height-adjustment functionality of the seatpost, please find the recommended clamping torque etched on the seatpost clamp or in the bicycle user manual.

2. PARTS LIST

- ❶ Saddle clamp body
- ❷ Upper tube
- ❸ Collar ring
- ❹ Lower tube
- ❺ Remote housing stop
- ❻ Remote control lever

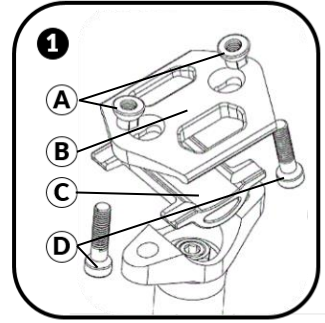
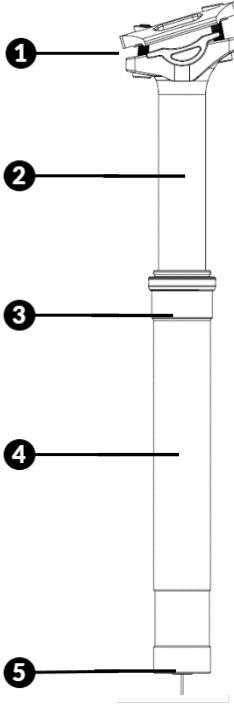

- ❶❸❹ A Saddle Clamp Nut (M6)
- ❶❸❹ B Saddle Clamp - Upper
(7 / 9 mm rail only)
- ❶❸❹ C Saddle Clamp - Lower
(7 / 9 mm rail only)
- ❶❸❹ D Saddle Clamp Bolt (M6 Hex),
Max Torque: 8.0 Nm |
70 lbs-in | 80 kgf-cm

3. SPECIFICATIONS

TRAVEL: 100MM

1	Travel	100mm
2	Total Length*	350mm
3	Max Extension	270mm
4	Min Insertion	80mm
5	Diameter	30.9mm

TRAVEL: 125MM

1	Travel	125mm
2	Total Length*	400mm
3	Max Extension	320mm
4	Min Insertion	80mm
5	Diameter	30.9mm

* A variation of $\pm 5\text{mm}$ overall length may be expected. This is normal and is due to manufacturing tolerance.

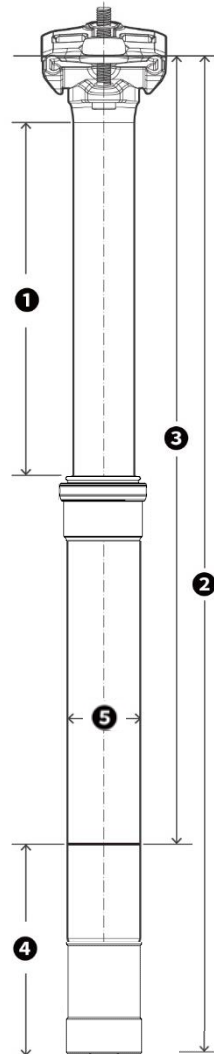

4. REMOTE LEVER OPTIONS

CONTACT SWITCH CORE



CONTACT SWITCH AT



GIANT VERTICAL REMOTE



An economical, brand new remote lever is now available.

Depends on your bike purchase, the corresponding remote lever can be one of (but not limited to) above styles.

GIANT CONTACT SWITCH CORE is compatible with all existing remote levers under GIANT product range.

5. INSTALLATION

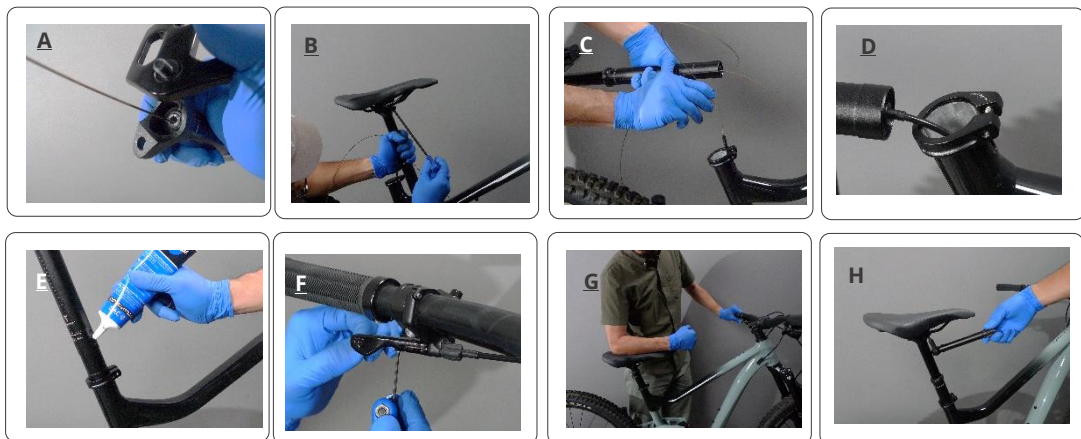

1. (Skip to Step 2 if you're building a new bike) Remove the existing seatpost and saddle from the bike before installing GIANT CONTACT SWITCH CORE.

2. Loosen and remove the rear saddle clamp bolt. The remote cable entry is now exposed **(A)**. Insert new remote cable. The cable passes through the post and exits from the bottom end.

3. Roughly install the saddle at level position. Tighten both clamp bolts for the moment **(B)**.

4. Feed the remote cable into the remote housing **(C)**. Then attach the ferrule onto the cable stop at the post bottom **(D)**.

5. Apply a thin layer of friction paste onto the post **(E)**, or into the frame seat tube. Insert the seatpost into seat tube until about midway between the min. insertion marking and the collar ring, then tighten the seatpost clamp according to the informed torque value*. Do not overtighten as this can upset the function of the seatpost.

*choose whichever is lower between the value etched on the post and the frame manufacturer's recommendations

4. Route the remote housing and cable according to the cable routing instruction of the frame manufacturer.

⚠CAUTION

It might be necessary to remove the crank and bottom bracket parts before routing the cable inside the frame. Please contact an authorized Giant dealer for assistance.

5. Install the remote control lever.

5.1 Mount the lever to the handlebar and fasten with 3mm hex key. Recommended torque: 3Nm | 26.55 lbs-in | 30.59 kgf-cm

5.2 Thread the cable through the barrel adjuster and insert cable housing securely.

5.3 Pull the cable taut and ensure the seatpost, cable housing, barrel adjuster, and remote lever are all attached correctly.

5.4 Fasten the clamping bolt using a 3mm hex key. Recommended torque: 1.2Nm | 10 lbs-in | 12kgf-cm **(F)**

5.5 Cut any excess cable.

⚠CAUTION

Add a cable end to the remote cable to prevent the cable from having a sharp end or to keep it from fraying.

6. Actuate the remote and test the operation changing high and low position. **(G)**

7. Adjust the saddle to the preferred height without breaching min. insertion requirement. Tighten all fastener according to recommended torque. **(H)**

⚠WARNING

Do not ride if the seatpost height-adjusting functionality does not function smoothly.

Do not ride if min. insertion is not achievable. Lack of post insertion can result in sudden failure and cause injury or even death.

Please contact an authorized Giant service center for more information.

6. OPERATION

⚠WARNING

Adjusting the seatpost height while the bike is in motion can result in loss of control.

- To lower the seat height:** Press the remote lever and push down or sit on the saddle to reach the preset lower saddle height. Then release the lever.
Please note that Contact Switch CORE is designed to stay at either high or low position. If the low position is failed to be reached after the remote lever is released, the post tends to return to the high position.

To raise the seat height: Remove the weight from the saddle and press the remote lever until the max. extension/height is achieved. Then release the lever.

7. CARE OF USE AND TROUBLESHOOT

Thanks to the integrated design with simplicity in mind, the new GIANT CONTACT SWITCH CORE does not require periodical maintenance.

After first couple rides, a small amount of grease may weep out from the collar ring area, this is normal. Simply wipe it off.

To ensure prolonged performance, please do clean the exterior either prior to, or after each ride. Use mild soapy water to clean off any attracted dirt or dust. To rinse with general hose water does not affect the longevity; however, jet wash should always be avoided in case of water ingress.

If the dropper post refuses to operate smoothly, or the installed position has changed (in most case, lower than before) over time, a quick re-installation may address this.

If in doubt, please contact your local authorized Giant dealer for assistance.

Action	Pre/Post each ride	Wiggling	Sinks down	Jammed
Clean, inspect	✓			
Consult authorized GIANT dealer		✓	✓	✓

8. GIANT LIMITED WARRANTY

Giant guarantees the GIANT CONTACT SWITCH CORE for a period of two (2) years from the date of purchase for the original owner only.

REQUIRED ASSEMBLY WHEN PURCHASED

This warranty applies only to this product when purchased new from an Authorized Giant or Liv Dealer and assembled by that dealer at the time of purchase.

LIMITED REMEDY

Unless otherwise provided, the sole remedy under the above warranty, or any implied warranty, is limited to the replacement of defective parts with those of equal or greater value at the sole discretion of Giant. This warranty extends from the date of purchase, applies only to the original owner, and is not transferable. In no event shall Giant be responsible for any direct, incidental or consequential damages, including, without limitation, damages for personal injury, property damage, or economic losses, whether based on contract, warranty, negligence, product liability, or any other theory.

EXCLUSIONS

The above warranty, or any implied warranty, does not cover:

- Normal wear and tear on parts in situations where there are no assembly or material defects.
- Products serviced by other than an authorized Giant dealer.
- Modifications of the product from its original condition.
- Use of this product for abnormal, competition and/or commercial activities or for purposes other than those for which this product was designed.
- Damage caused by failing to follow the instructions in this manual..
- Paint, finish and decal damage resulting from taking part in competitions, jumping, downhill and/or training for such activities or events or as a result of exposing the product to, or operating the product in, severe conditions or climates.
- Labor charges for part replacement or changeover.

Except as is provided by this warranty and subject to all additional warranties, Giant and its employees and agents shall not be liable for any loss or damage whatsoever (including incidental and consequential loss or damage caused by negligence or default) arising from or concerning any Giant product.

Giant makes no other warranties, express or implied. All implied warranties, including the warranties of merchantability and fitness for a particular purpose are limited in duration to that of the express warranties stated above.

Any claim against this warranty must be made through an Authorized Giant Dealer or distributor. The purchase receipt or other proof of the date of purchase is required before a warranty claim may be processed. Claims made outside the country of purchase may be subject to fees and additional restrictions. Warranty duration and details may differ by country. This warranty gives you specific legal rights, and you may also have other rights which may vary from place to place. THIS WARRANTY DOES NOT AFFECT YOUR STATUTORY RIGHTS.

SERVICE CENTERS

To find a Giant retailer near you, please visit: www.giant-bicycles.com