

CADEX

TUBELESS TIRE

A.

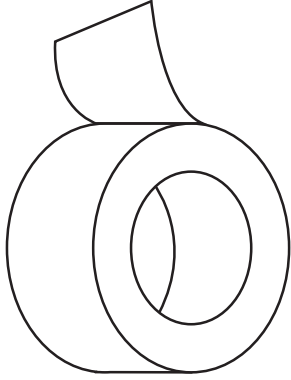

B.

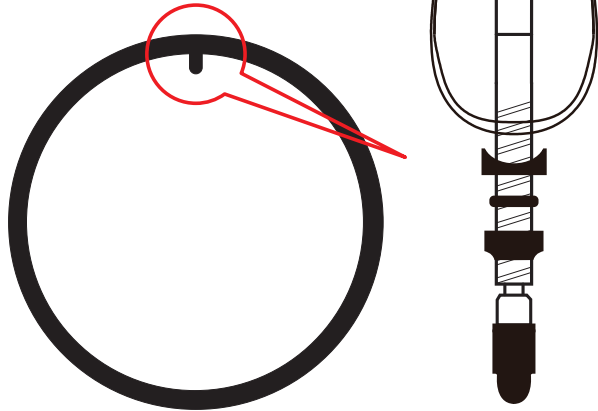

C.

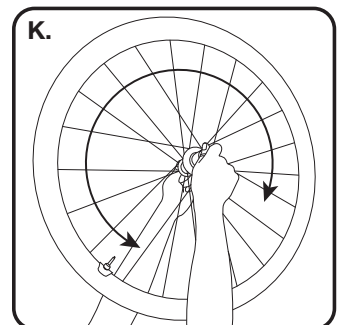
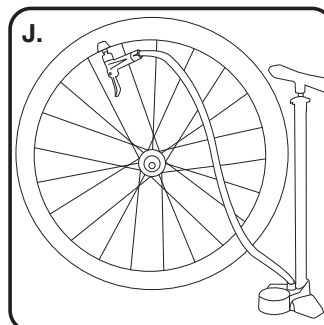
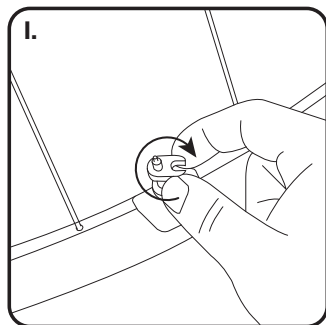
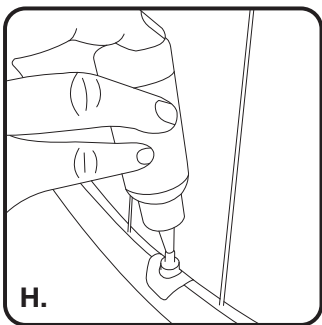
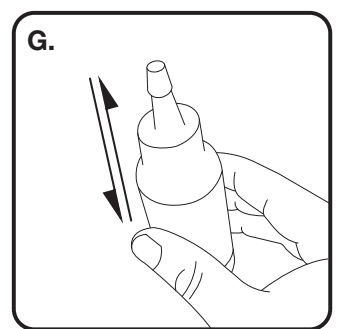
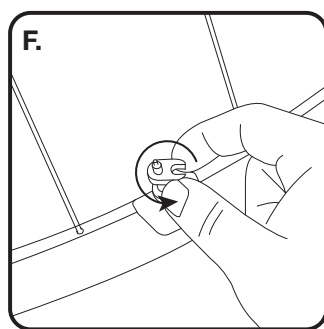
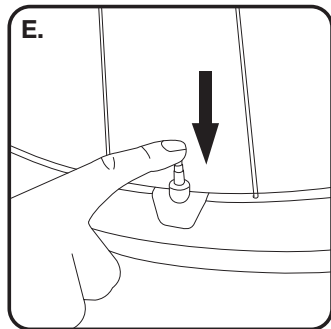
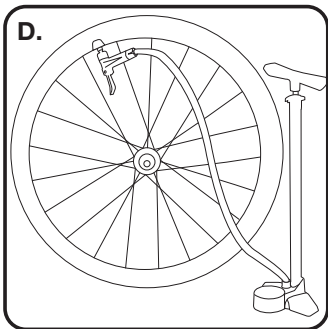
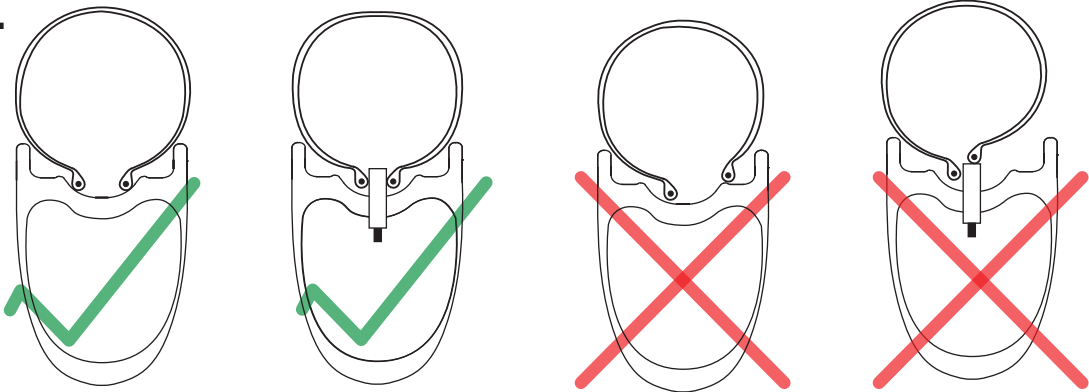

CADEX Tubeless Tires use a coating on the inside of the casing to enhance the tire's air retention properties. As this coating is vulnerable to damage from tire levers, it is recommended to install and remove the tire without using tire levers or by using CADEX's specifically designed tubeless tire lever.

CADEX tubeless systems require the use of sealant for proper air retention.

TUBELESS TIRE INSTALLATION

1. Starting opposite the inflation valve, install the first tire bead into the rim center channel. Working your way around the rim, press the remainder of that bead into the rim center channel on the appropriate side of the valve.(C)
2. Starting opposite the valve, install the other bead into the rim center channel, working towards the valve.(C)
3. Prior to adding tire sealant, inflate tire until both beads have seated onto the rim. DO NOT exceed the maximum inflation pressure of the rim or tire. Visually confirm proper seating of the tire on the rim (the safety line on the tire and edge of the rim should be concentric).(D)
- NOTE 1: The tire and rim are not airtight until both beads are seated on the rim; air may leak from the system during initial inflation.
- NOTE 2: High volume air flow aids in initial inflation; if you are having difficulty, try removing the core of the valve with the included small tool and inflate using either the Giant Control Tank or Control Tower Boost or an air compressor.
- NOTE 3: CADEX Tubeless systems require the use of tire sealant for proper air retention. DO NOT ride until the appropriate amount of sealant has been added.
4. Upon achieving initial inflation, slowly deflate the tire entirely and follow the next steps to add the sealant to the system. If you have any problems, please refer to the FAQ.
5. It is much cleaner and quite easy to add sealant through the valve. To do this, with the tire deflated, use the included tool to unscrew and remove the core from the valve entirely (if not already).(F)
6. Before opening, shake the sealant bottle to ensure that particulates are distributed within the liquid.(G)
7. Using the nipple on the bottle, or your own approved solution, add sealant to the seated tire via the core-less valve.(H)
- NOTE: Follow sealant manufacturer's recommendation for sealant volume; too much sealant can reduce rolling efficiency and does not enhance the sealing capabilities of the material; too little and air leakage will occur. Suggested quantity, depending on tire size, is 30-60ml.
- NOTE: Please only use sealant provided by Giant or made by Stan's NoTubes. Other brand sealants have not been approved by CADEX's tubeless systems and their performance is not guaranteed and void of your warranty.
8. Re-install the tubeless valve core using the included tool. Ensure that the valve core is firmly seated within the valve. Incorrect reassembly will prevent the system from being airtight and could lead to sudden deflation.(I)
9. With the valve core installed in the valve and confirmed in the "open" position, inflate to the maximum pressure as indicated on the tire. This is to aid with sealant dispersion in the tire.(J)
10. During Step 8, it is possible some air will continue to leak as the sealant has not yet completely covered the inside of the tire. To address this, hold the wheel by the axles in your hands, gently spin the wheel and shake the wheel as it rotates. Another option is to ride the bike for a short period. Be sure to confirm minimum inflation pressure prior to riding. This will spread the sealant and fill any small holes allowing air to escape.(K)
11. Inflate tire to riding pressure and reinstall your wheels; your bike is ready to ride.
12. If you continue to have problems, please contact your Authorized CADEX Retailer for further assistance.

TUBELESS TIRE INSTALLATION FAQ

The sealant is thin and doesn't appear to seal the system.

- Giant sealant is a milky white fluid. Prior to use, please shake the sealant container well to allow particulates to be distributed within the liquid.
- Follow sealant supplier's recommendation for proper storage and replacement frequency.

I am not able to achieve initial inflation (completely seat beads).

- Ensure that both tire beads are pinched together in the rim center channel and surrounding the valve, prior to inflation.
- Add a small amount (15cc) of sealant through the open valve. This aids in lubrication and can allow the tire to seat more easily.
- Follow NOTES 2 suggestions in Step 4.

How do I remove the tire?

- Deflate the tire entirely. Working around the tire, push both tire beads away from the rim edge and into the center channel of the rim. Push one bead over the top of the rim, starting at the tubeless valve, and work around the rim until the bead is off entirely. Again, starting at the valve, push the other bead off the rim and work all the way around the rim. Your tire is off. If you find it necessary to use a tire lever, it is recommended to use the CADEX Tubeless Tire lever and be careful not to damage the tire casing, tire bead or rim.

The tire beads are deformed due to packaging or shipping, and cannot achieve initial inflation.

- Install an inner tube in the wheel/tire assembly, inflate to maximum pressure and leave for 12+ hours. The tire should no longer be deformed.

Tire punctures are sometimes inevitable with a tube type or tubeless system. You can reduce your risk of tire punctures by paying attention to the surfaces ridden on and avoiding obvious items that can cause punctures.

The tire has no visible puncture but continues to leak air.

Please follow the steps below to check:

- Make sure the valve is airtight; overtightening of the valve nut, insecure valve core or sealant buildup are common issues.
- Make sure there is enough liquid sealant, add 15cc more if necessary.
- Remove the tire and check the high-pressure rim tape for any cracks or cuts, especially at the edge of spoke holes. While the tire is removed, please also check that the rubber at the valve is properly seated in the center channel and that there is no damage to the rubber or the tape.
- Check the rim for any cracks or other damage.

If the tire is punctured, should the part causing the damage be removed?

- Yes, removal of the damaging part is recommended. Otherwise further damage to the tire may occur.
- If the puncture is too large for the sealant to work, repair the tire casing with a booting material as required and install an inner tube for an emergency solution.
- If a hole is too large for the sealant to work, the tire structure has been compromised. Even if it functions with a tire patch and inner tube, CADEX cannot guarantee the functionality and riding safety of a tire in that condition.