

GIANT Power Pro V3 User Manual

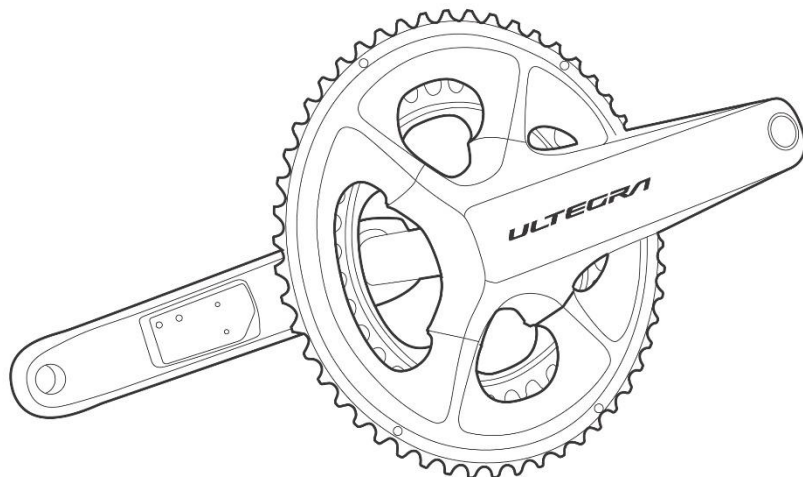

INTRODUCTION

Congratulations on the purchase of your new Giant Power Pro V3. The all-new Giant Power Pro V3 is a crank-based, true dual side power meter with increased precision. Power Pro power meter makes training with power more accessible to more riders everywhere and features built-in gyro sensors that help compensate for ground surge impacts occurring on uneven surfaces, delivering clean and accurate data through an integrated system that's precise, reliable and simple to set up. Giant Power Pro V3 is powerful in a simplified package for all enthusiast riders.

PRODUCT ANATOMY

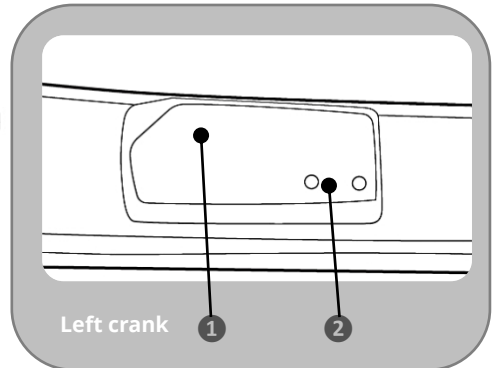
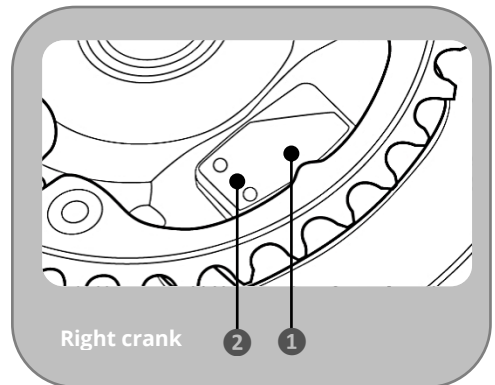
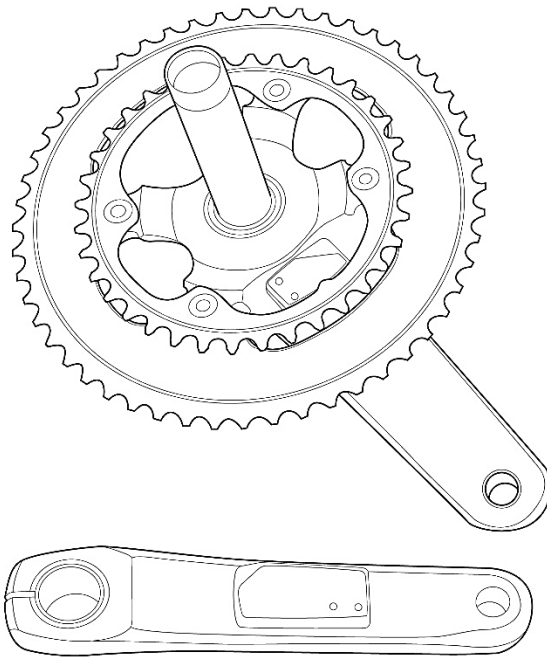

- ① LED INDICATION LIGHT
- ② MAGNETIC CHARGING PORT

CHARGING CABLE

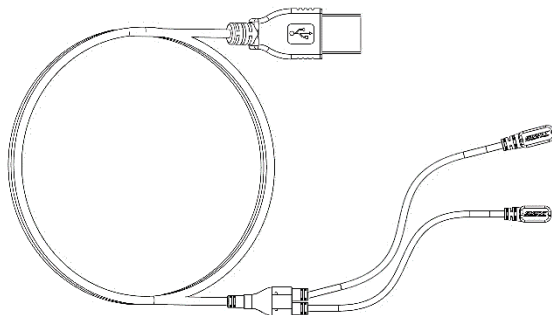

Every GIANT Power Pro V3 comes with a dedicated charging cable. Please make sure that this cable is included when purchasing Power Pro.

Please note that the USB charger is not included.

LED INDICATIONS

There is a LED indicator light on both side of Giant Power Pro V3. This indicator light shows various conditions.

Waking up Power Pro V3:

Simply by rotating the crank arm backwards 2 or 3 full turns:

- Indicator light blinks GREEN 10 times ● · ● · ● : Battery capacity is more than 60%
- Indicator light blinks YELLOW 10 times ● · ● · ● : Battery capacity is between 30~60%
- Indicator light blinks RED 10 times ● · ● · ● : Battery capacity is less than 30%

While charging:

- Indicator light is RED ● ● ● ● ● : Charging is in progress.
- Indicator light is GREEN ● ● ● ● ● : Charging is complete.

Indicator light does not light up or blink:

The battery may be damaged or the unit has other problems, please contact an authorized Giant retailer for assistance.

IMPORTANT NOTICE BEFORE RIDING

We strongly urge you to read the Bicycle Owner's Manual thoroughly before your first ride. Read and make sure that you understand every point in this manual, especially the "Safety" section. If you have any questions, please contact your local authorized Giant retailer.

This user manual contains important safety, performance, and service information. Please read the user manual before starting to use your new **Giant Power Pro V3** and keep it for future reference.

For your safety, we recommend that you to focus on your surroundings while riding. Avoid staring at the cycle computer or smartphone screen. This may compromise your traffic awareness, and possibly lead to serious accident.

SERVICE AND TECHNICAL SUPPORT

If you encounter difficulties or are uncertain about anything mentioned in this user manual, please contact an authorized Giant retailer,



or visit: <https://www.giant-bicycles.com/global/showcase/power-pro>



For more information, please visit:

<https://www.giant-bicycles.com/global/manuals>

To find a dealer or to learn more about Giant, please visit: www.giant-bicycles.com

QUICK START

1. CHARGING THE BATTERY

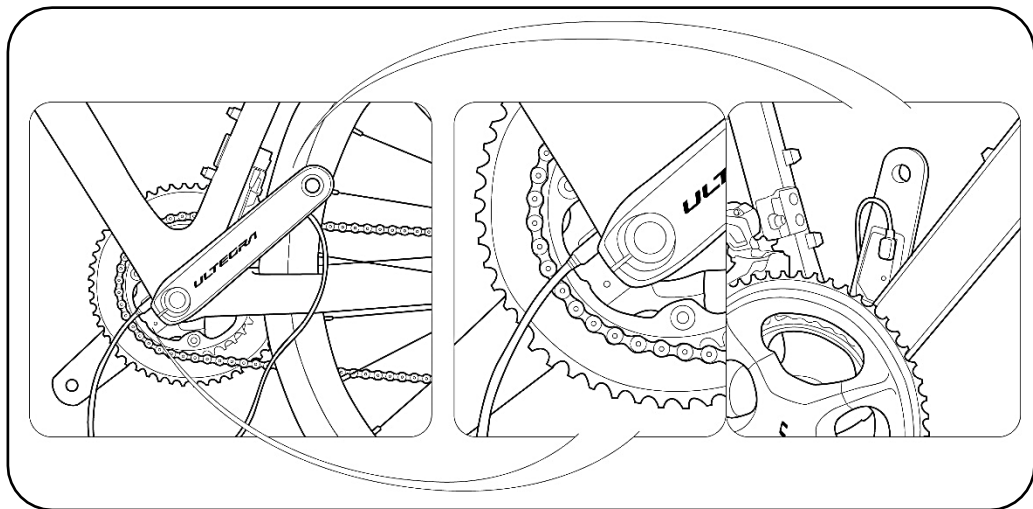

Connect the charging cable to a USB power source. For best results, we recommend using a dedicated USB charger with output current of 1~2A.

Connect the cable to the charging port on GIANT Power Pro V3. The unit should start charging immediately.

Fully charge the battery of Power Pro V3 before using it for the first time.

Indicator light is RED ●●●●●: Charging is in progress.

Indicator light is GREEN ●●●●●: Charging is complete.

⚠ CAUTION

Input voltage: 5V±10%

Input current: 1~2A

Charging time: Approximately 1 hour for a full charge.

The battery should be fully recharged once every 2 months when Power Pro V3 is not being used for a longer time.

2. PAIRING WITH CYCLING COMPUTER OR RIDELINK APP

GIANT Power Pro V3 is compatible with cycling computers that have BLUETOOTH and ANT+ functions and ability to record power information.

1. Rotate the crank arm backwards two or three full turns to wake up Giant Power Pro V3.
2. The Indicator light blinks showing its battery status.
3. Refer to the user manual of the cycling computer to pair with Power Pro V3. The pairing procedures may differ between various brands.

Below shows the pairing process with a **GIANT DASH M200** cycling computer.

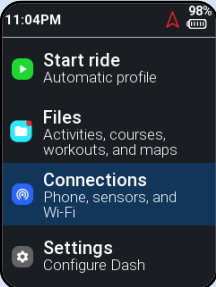
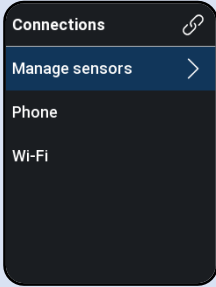
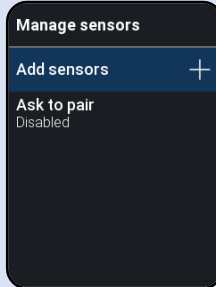
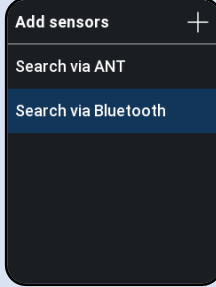
<p>Step 1</p>  <p>Select Connections</p>	<p>Step 2</p>  <p>Select Manage sensors</p>	<p>Step 3</p>  <p>Select ADD sensors</p>	<p>Step 4</p>  <p>Select Search via Bluetooth</p>
--	--	---	---

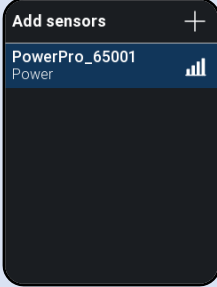
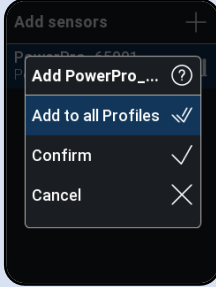
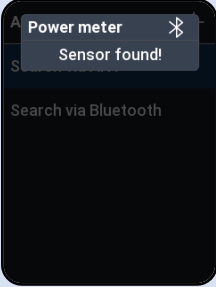
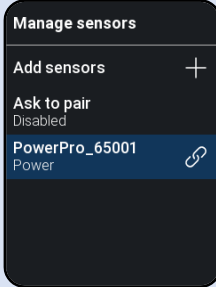
<p>Step 5</p>  <p>Select your Power Pro</p>	<p>Step 6</p>  <p>Select Add to all Profiles or Confirm</p>	<p>Step 7</p>  <p>Confirmation message pops out</p>	<p>Step 8</p>  <p>Your Power Pro is now ready to use</p>
--	--	--	--

Alternatively, Giant Power Pro V3 can also be paired with GIANT RideLink APP via your smart phone. The pairing procedure is similar:

1. Download and install GIANT RideLink APP from Google Play (Android) or APP Store(iOS)
2. Rotate the crank arm backwards two or three full turns to wake up Power Pro V3.
3. The Indicator light blinks showing its battery status.
4. Follow the instructions from the GIANT RideLink APP to pair with Power Pro V3.

Below shows the pairing process with **GIANT RideLink APP**.

Step 1



Tap **Power Meter**

Step 2

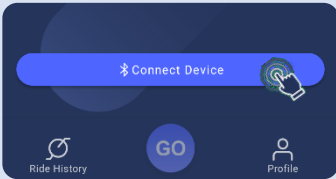

Tap **Connect Device**

Step 3

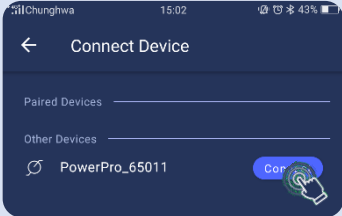

Find your Power Pro and tap **Connect**

Step 4

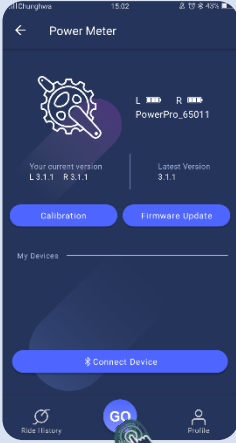

Once connected, the RideLink shows **current battery status, firmware version and available update**.

Tap **GO** to start using your Power Pro

3. CALIBRATE/ZERO RESET

For best results, it is recommended to perform the calibration procedure before every ride. Some APPs, or cycling computer may refer it as *Zero Offset*, or *Zero Reset*, which is exactly the same thing. This is the most essential process and it only takes seconds.

Before the calibration, keep the driveside crank arm in 12 o'clock position while the bike is positioned horizontally. Leave the crank in stationary position.

Do not attempt the calibration procedure while you're on the bike. Do not Apply any force on the pedals, either.

Refer to the manufacturer's user manual of the cycling computer to calibrate with Power Pro V3. The procedures may differ between different computer brands, but in general it's very similar.

During the process of calibration, you should find indicator lights from both cranks blink BLUE ● • ● • ● for a few times.

Once the calibration is successful, you may get a confirmation message "successful" or "0" from the computer.

Below shows how to calibrate with **GIANT RideLink APP**.

Step 1

Tap **Calibration**



Then tap **Yes**

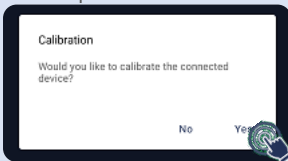

Step 2

Position the right-hand crank at 12 o'clock.

Tap **Start Calibration**



Step 3

Calibration should take less than a few seconds.

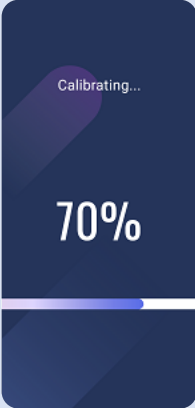

Step 4

Once completed, tap **Done** and you're ready to ride.

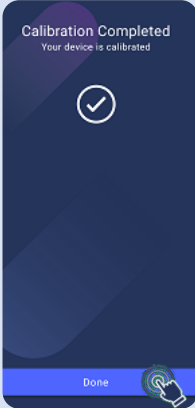

Below shows how to **Zero reset** with a GIANT DASH M200 cycling computer

Step 1	Step 2	Step 3	Step 4
 <p>Manage sensors</p> <p>Add sensors +</p> <p>Ask to pair Disabled</p> <p>PowerPro_65001 Power</p>	 <p>PowerPro_65001</p> <p>Status Enabled</p> <p>Zero reset</p> <p>Rename</p> <p>Delete sensor</p> <p>Communication prot...</p> <p>Added to all profiles</p>	 <p>Zero reset</p> <p>Zero reset in progress...</p> <p>Zero reset</p> <p>Rename</p> <p>Delete sensor</p> <p>Communication prot...</p> <p>Added to all profiles</p>	 <p>Zero reset</p> <p>Success!</p> <p>Zero reset</p> <p>Rename</p> <p>Delete sensor</p> <p>Communication prot...</p> <p>Added to all profiles</p>
<p>Enter the Manage sensors page.</p> <p>Select your Power Pro</p>	<p>Select Zero reset</p>	<p>(Zero reset in progress...)</p>	<p>(Zero reset Success!)</p> <p>You are ready to ride.</p>

RIDELINK APP AND FIRMWARE UPDATE

Giant continuously keeps developing and releasing the updated versions of firmware to provide the latest functionalities. The latest firmware version for Giant Power Pro V3 can be updated by using Giant RideLink APP.

The Giant RideLink APP is available for Apple® iOS and Android system. Please go to the App Store® or Google Play to search Giant RideLink APP and download it.



SPECIFICATIONS

Dependent crank	SHIMANO ULTEGRA FC-R8100
Compatible chainring ratio	50/34T, 52/36T
Crank length options	165mm / 170mm/172.5mm/175mm
Connections (BLE/ANT+)	BLE/ANT+
Battery type	Lithium-ion
Battery running time	100 hours
Battery charge time	1 hour
State of charge indicator (Y/N)	Yes
Accuracy	± 2%
Temperature compensation	Yes
Left/Right balance (Y/N)	Yes
Firmware APP	GIANT RideLink
Water resistance capability	IPX7
Intended use	Road, Gravel cycling

MAINTENANCE AND WATER RESISTANCE

To ensure the functionalities of Giant Power Pro V3 and not to affect the Giant limited warranty, please make sure to comply with the WARNINGS and CAUTIONS listed below. Not complying with these may result in damaging Giant Power Pro V3 and void your warranty.

The water resistance level of Giant Power Pro V3 complies with the IPX7 rating.

⚠ WARNING

Do NOT immerse Power Pro V3 in water.

Do NOT use the high pressure washers to clean the power meter directly. The high pressure will cause the moisture to permeate the internals of the power meter and damage the electronic components.

Do NOT disassemble Power Pro V3, this will void your warranty.

Only clean the cover of power meter with a clean cloth and water. Please do NOT use chemical detergent to clean as it may damage the cover.

Do NOT expose Power Pro V3 to constant high temperatures.

Avoid that Power Pro V3 gets hit by any abnormal external force which may cause damage to the components.

Stop charging immediately to avoid dangerous situations if a strange smell, smoke, or any other abnormal condition occurs during charging.

Do not charge the battery in a wet environment or during a thunderstorm. It may cause damage to the battery and possible dangerous situations such as an electric shock.

Make sure that no metal items or oily materials that short the charging connectors or charging terminals.

⚠ CAUTION

The storage environment temperature range is between $-30^{\circ}\text{C} \sim 80^{\circ}\text{C}$ / $-22^{\circ}\text{F} \sim 176^{\circ}\text{F}$. Damage to the electronic components may occur if the storage temperature is out of range.

The operating environment temperature range is between $-20^{\circ}\text{C} \sim 50^{\circ}\text{C}$ / $-4^{\circ}\text{F} \sim 122^{\circ}\text{F}$. The functions may not be normal when the temperature is out of range.

The environment temperature should be between $-20^{\circ}\text{C} \sim 50^{\circ}\text{C}$ / $-4^{\circ}\text{F} \sim 122^{\circ}\text{F}$ when charging the battery. The battery may get damaged when the environment temperature is out of range.

Only use the charging cable which is supplied with Power Pro V3. Do not bundle the charging cable while charging. Do not pull or damage the charging cable in any way. Using a damaged charging cable may cause danger.

Follow the suggested voltage and current: $5\text{V} \pm 10\% / 1 \sim 2\text{A}$.

Charging time is around 1 hour. If the charging time is over 1 hour and the battery is still not fully charged, stop charging to avoid the risk of overheating the battery. Please contact your local authorized Giant retailer for support and advice.

The battery should be fully recharged once every two months when the power meter is not being used for a longer time.

The battery may get damaged if it does not get charged at low battery level. Charge it at any time.

It is a normal phenomenon that the battery level will gradually reduce when it has not being used for a period of time.

A loss of no more than 30% of its original nominal capacity at a maximum of 400 charges is to be expected.

GIANT LIMITED WARRANTY

Giant warrants its power meter for a period of two (2) years from the date of purchase, this Applies only for the original owner. This warranty Applies only to this product when purchased new from an Authorized Giant Dealer and assembled by that dealer at the time of purchase.

1. LIMITED REMEDY

Unless otherwise provided, the sole remedy under the above warranty, or any implied warranty, is limited to the replacement of defective parts with those of equal or greater value at the sole discretion of Giant. This warranty extends from the date of purchase, Applies only to the original owner, and is not transferable. In no event shall Giant be responsible for any direct, incidental or consequential damages, including, without limitation, damages for personal injury, property damage, or economic losses, whether based on contract, warranty, negligence, product liability, or any other theory.

2. EXCLUSIONS

2.1. The above warranty, or any implied warranty, does not cover:

- Normal wear and tear on parts in situations where there are no assembly or material defects.
- Consumable components including bolts and charging cable.
- Products serviced by other than an Authorized Giant dealer.
- Modifications of the product from its original condition.
- Use of this product for abnormal, competition and/or commercial activities or for purposes other than those for which this product was designed.
- Damage caused by failing to follow the User's Manual.
- Paint, finish and decal damage resulting from taking part in competitions, jumping, downhill and/or training for such activities or events or as a result of exposing the product to, or operating the product in, severe conditions or climates.
- Labor charges for part replacement or changeover.

2.2. Except as is provided by this warranty and subject to all additional warranties, Giant and its employees and agents shall not be liable for any loss or damage whatsoever (including incidental and consequential loss or damage caused by negligence or default) arising from or concerning any Giant product.

2.3. Giant makes no other warranties, express or implied. All implied warranties, including the warranties of merchantability and fitness for a particular purpose are limited in duration to that

of the express warranties stated above.

2.4. Any claim against this warranty must be made through an Authorized Giant Dealer or distributor. The purchase receipt or other proof of the date of purchase is required before a warranty claim may be processed.

2.5. Claims made outside the country of purchase may be subject to fees and additional restrictions. Warranty duration and details may differ by country. This warranty gives you specific legal rights, and you may also have other rights which may vary from place to place.

THIS WARRANTY DOES NOT AFFECT YOUR STATUTORY RIGHTS.